



MARATHON COUNTY SOLID WASTE MANAGEMENT BOARD AGENDA

Date & Time of Meeting: Monday, August 12th, 2024, at 2:00 pm

Meeting Location: Large Conference Room, 210 River Drive, Wausau, WI 54403, or Webex

Marathon County Mission Statement: *Marathon County Government serves people by leading, coordinating, and providing county, regional, and statewide initiatives. It directly or in cooperation with other public and private partners provides services and creates opportunities that make Marathon County and the surrounding area a preferred place to live, work, visit, and do business. (Last updated: 12-20-05)*

Mission Statement: *To provide the residents, businesses, and organizations of the region with a cost effective, comprehensive integrated waste management system. The system consists of programming, education and consulting services on waste reduction, recycling, composting and hazardous waste management, along with landfill disposal, with landfill-gas-to-energy production.*

Members: Thomas Seubert – Chair, Jean Maszk - Vice-Chair, Tim Sondelski, Kerry Brimmer, Tim Sondelski, Jason Wilhelm, Harlyn Woodward, Al Christiansen, Allen Drabek and Marylin Bhend

Persons wishing to attend the meeting by Webex/phone may call into the **telephone conference ten (10) minutes prior to the start time indicated above using the following number:**

Phone Number: +1-408-418-9388

Access Code/Meeting Number: 2495 718 4126

Please Note: If you are prompted to provide an “Attendee Identification Number” enter the # sign. No other number is required to participate in the telephone conference.

When you enter the telephone conference, **PLEASE PUT YOUR PHONE ON MUTE!**

1. **Call Meeting to Order**
2. **Public Comment-**
3. **Approval of the Minutes of the June 10th, 2024, Meeting**
4. **Educational Presentations / Outcome Monitoring Reports and Possible Action:**
 - A. Operations Update: Compactor, Area B Closure, RNG
 - B. Presentation and Discussion with Foth Environmental
 1. Audit of Marathon Portage Shawano Regional Solid Waste Agreement
 2. Review of Solid Waste Financials
5. **Policy Issues Discussion and Committee Determination to the County Board for its Consideration and Possible Action:**
 - A. Vault Toilet for CWOCC – Requesting Partial Support
 - B. 2025 FTE Request for RNG support position
6. **Next Regular Meeting Time, Location, Agenda Items and Reports to the County Board–**
Committee Members are asked to bring ideas for future discussion; next meeting September 9th, 2024.

7. Announcements / Requests

8. Adjournment

Any person planning to attend this meeting who needs some type of special accommodation in order to participate should call the County Clerk's Office at 715-261-1500 one business day before the meeting.

SIGNED /s/ 
Presiding Officer or Designee

EMAILED TO:
News Dept. at Daily Herald, TPP Printing, Marshfield News,
Midwest Radio Group, Record Review
Date: _____
Time: _____
By: _____
Date/Time/By: _____

NOTICE POSTED AT COURTHOUSE:
Date: _____
Time: _____ a.m. / p.m.
By: _____

Marathon County Solid Waste Management Board 2020-2025 Strategic Goals

1. Maximize economic opportunities from landfill operations.
2. Engage Marathon County residents and businesses to divert solid waste into productive use such as but not limited to hazardous household, food, and construction and demolition.
3. Make recycling easy and understandable.
4. Shift the paradigm to alternative uses for waste.
5. Influence state policy in order to make the highest and best uses of waste resources.



**MARATHON COUNTY
SOLID WASTE MANAGEMENT BOARD
June 10th, 2024, MINUTES**

Attendance:

	<u>Present</u>	<u>Not Present</u>
Thomas Seubert - Chair	X	
Jean Maszk – Vice Chair	X	
Kerry Brimmer	X	
Marilyn Bhend	X	
Allen Drabek	X	
Tim Sondelski	X	
Jason Wilhelm		X
Harlyn Woodward		X
Al Christensen	X	

Also present: Dave Hagenbucher- (SWD), Laurie Miskimins– Conservation, Planning, and Zoning (CPZ)

1. Call Meeting to Order

A. The agenda being properly signed and posted, and the presence of a quorum, the meeting was called to order at 2:01pm by Director Hagenbucher at the Solid Waste Department, Landfill Site.

B. Election of Chair and Vice Chair

Action: MOTION BY DRABEK/CHRISTENSEN TO NOMINATE SEUBERT FOR CHAIR.

Director Hagenbucher called three time for additional nominations.

Action: MOTION BY BHEND/CHRISTENSEN TO CLOSE THE NOMINATIONS AND CAST A UNANIMOUS VOTE FOR SEUBERT FOR CHAIR. MOTION CARRIED BY VOICE VOTE, NO DISSENT.

Chair Seubert was sat as chair at 2:03 PM. Chair Seubert called for nominations for Vice Chair.

Action: MOTION/SECOND BY CHRISTENSEN/BRIMMER TO NOMINATE MASZK FOR VICE CHAIR.

Chair Seubert called three times for additional nominations.

Action: MOTION/SECOND BY BHEND/CHRISTENSEN TO CLOSE THE NOMINATIONS AND CAST A UNANIMOUS VOTE FOR MASZK FOR VICE CHAIR. MOTION CARRIED BY VOICE VOTE, NO DISSENT.

C. Public Comment – NONE

2. Approval of the Minutes of the May 13th, 2024, Meeting

ACTION: MOTION / SECOND BY MASZK/DRABEK TO APPROVE THE MAY 13TH, 2024, MINUTES. MOTION CARRIED BY VOICE VOTE, NO DISSENT.

3. Educational Presentations / Outcome Monitoring Reports and Possible Action

A. CIP Projects for 2025 Submitted

Hagenbucher reviewed CIP requests. Proposals include mostly equipment and scales, installation of vertical and horizontal gas wells. The CIP does not require approval by SWMB currently. This is just informational.

The board discussed questions related to specific CIP projects.

The board also asked the Director about other funding sources for PFAs in leachates and the disposal of these leachates. The Director explained that they are looking into funding sources for this disposal, and he would expand upon this in a presentation at another SWMB meeting.

FOLLOW-UP: The Director will include a topic on leachate funding on a future agenda for SWMB.

B. Budget Year to Date

The packet included multiple budget to actual reports by Solid Waste Department (SWD) program/site area. Eighteen percent of the annual budget has been expended year to date, Given the amount of rain this year, 18% is a very good place for the SWD to be in expenditures. Closing Area B should reduce leachate and the costs associated with leachate significantly in the future.

The board discussed other future items that may affect the budget, including contributions to the County Budget, royalties from the RNG, and where those royalties could go.

C. Operational Updates and Site Tour (optional; moved to after adjournment)

4. **Policy Issues Discussion and Committee Determination to the County Board for its Consideration and Possible Action** – None

5. **Next Regular Meeting Time, Location, Agenda Items and Reports to the County Board**

Committee Members are asked to bring ideas for future discussion; next regular meeting August 12th, 2024. The meeting will be held at Conservation, Planning, & Zoning Large Conference Room, located 210 River Drive, Wausau, WI. It was clarified that no meeting will be held Monday, July 8th.

6. **Announcements / Requests**

7. **Adjournment Meeting was adjourned at for optional tour of the Solid Waste Landfill Site**

ACTION: MOTION / SECOND BY MASZK/CHRISTIANSEN TO ADJOURN THE MEETING AT 2:34PM. MOTION CARRIED BY VOICE VOTE, NO DISSENT.

Post Adjournment an optional educational tour of the Solid Waste Landfill Site was provided to Interested Participants.

Respectfully submitted,
David Hagenbucher
Director- Solid Waste Department
DH:LM June 10th, 2024

7. Announcements / Requests

8. Adjournment

Any person planning to attend this meeting who needs some type of special accommodation in order to participate should call the County Clerk's Office at 715-261-1500 one business day before the meeting.

SIGNED /s/ 
Presiding Officer or Designee

EMAILED TO:
News Dept. at Daily Herald, TPP Printing, Marshfield News,
Midwest Radio Group, Record Review
Date: _____
Time: _____
By: _____
Date/Time/By: _____

NOTICE POSTED AT COURTHOUSE:
Date: _____
Time: _____ a.m. / p.m.
By: _____

Marathon County Solid Waste Management Board 2020-2025 Strategic Goals

1. Maximize economic opportunities from landfill operations.
2. Engage Marathon County residents and businesses to divert solid waste into productive use such as but not limited to hazardous household, food, and construction and demolition.
3. Make recycling easy and understandable.
4. Shift the paradigm to alternative uses for waste.
5. Influence state policy in order to make the highest and best uses of waste resources.

- VAULT -

TEAL

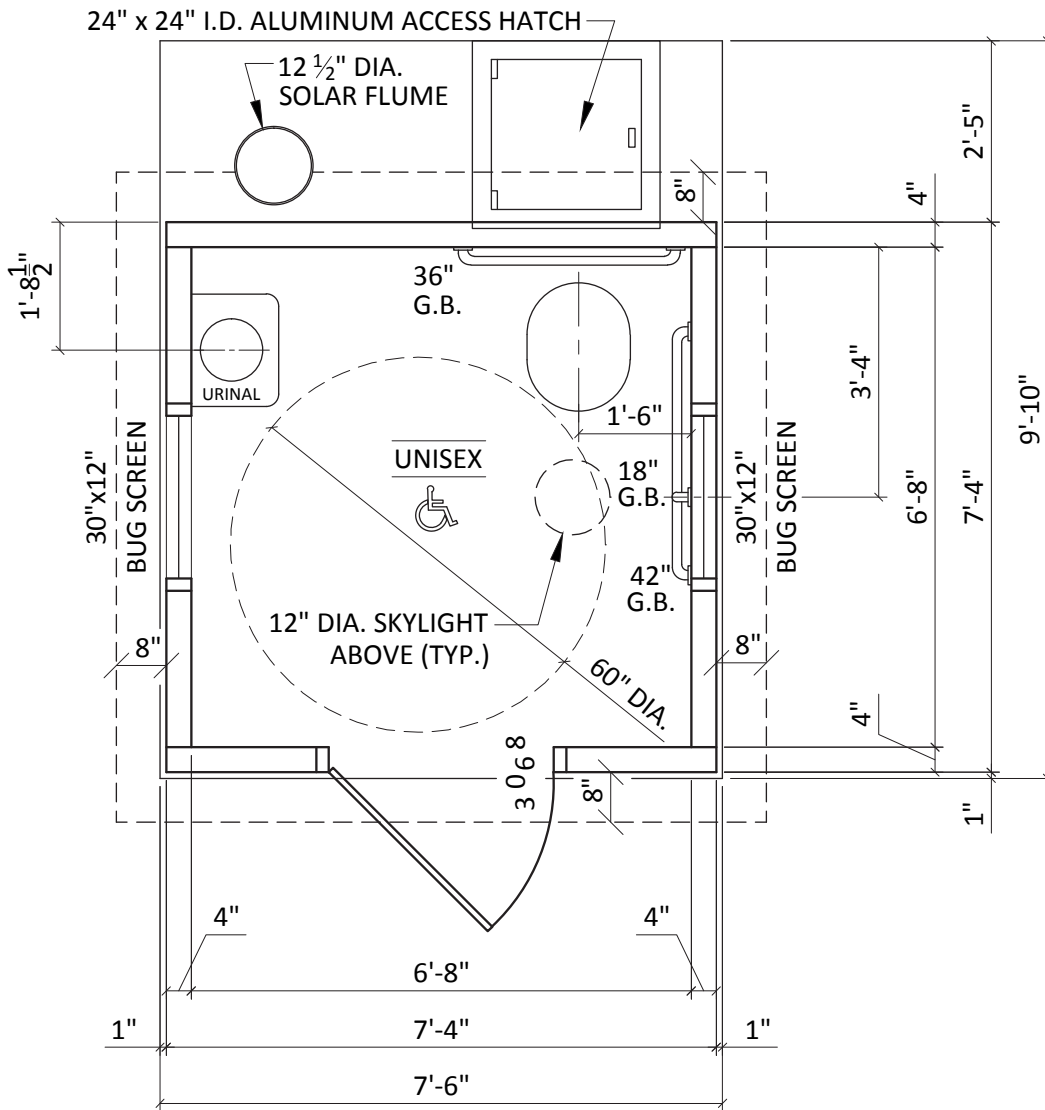

1 FLOOR PLAN
SCALE: 3/8" = 1'-0"



Floor plans are for reference only. This drawing shall not be copied or submitted to others without the consent of this company.

4154 123rd St. Chippewa Falls, WI 54729 | 715-723-7446
HUFFCUTT.COM

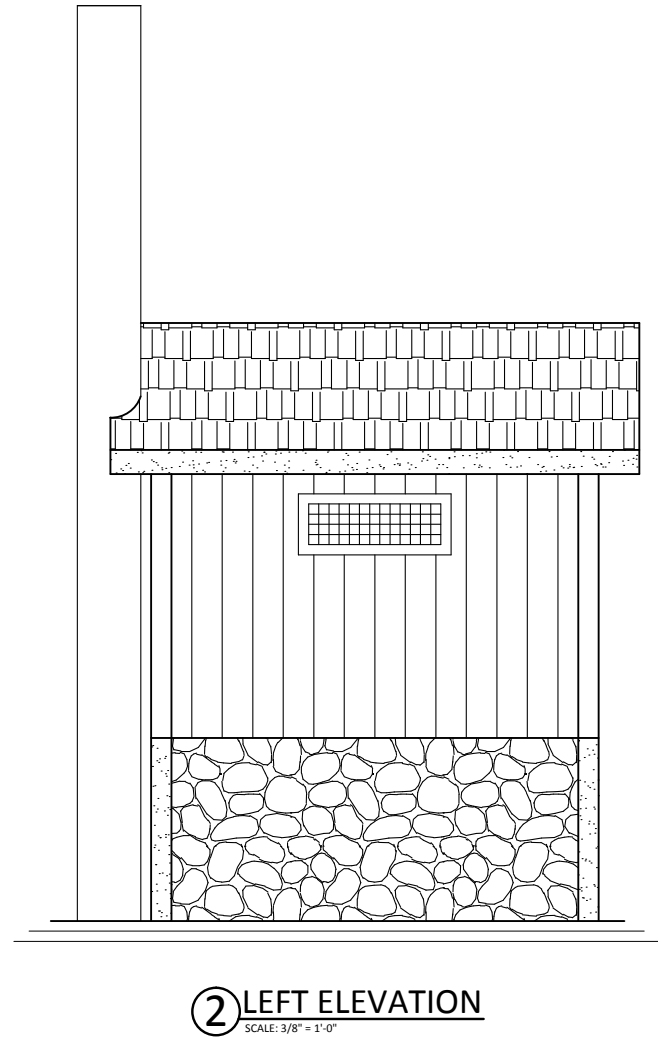
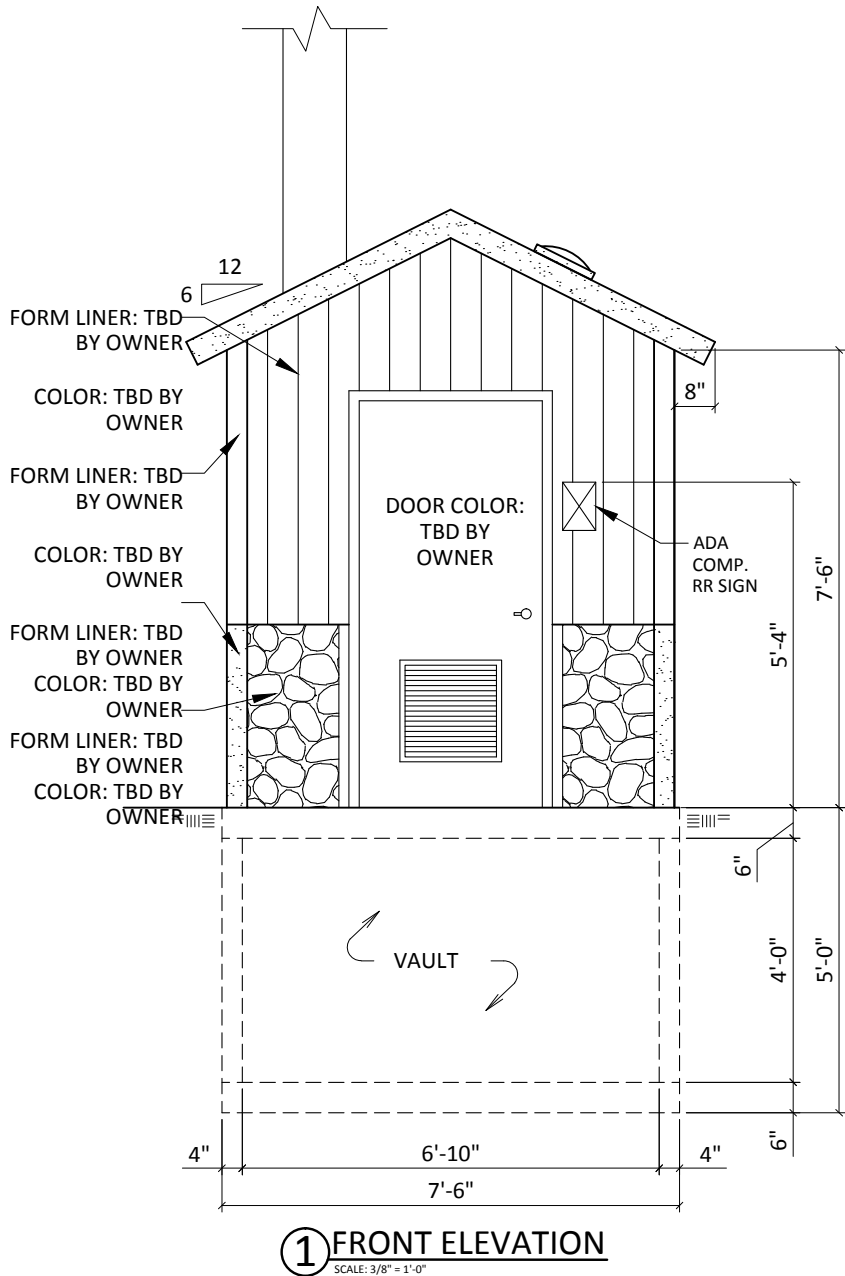

Floor plans are for reference only. This drawing shall not be copied or submitted to others without the consent of this company.

4154 123rd St. Chippewa Falls, WI 54729 | 715-723-7446
HUFFCUTT.COM

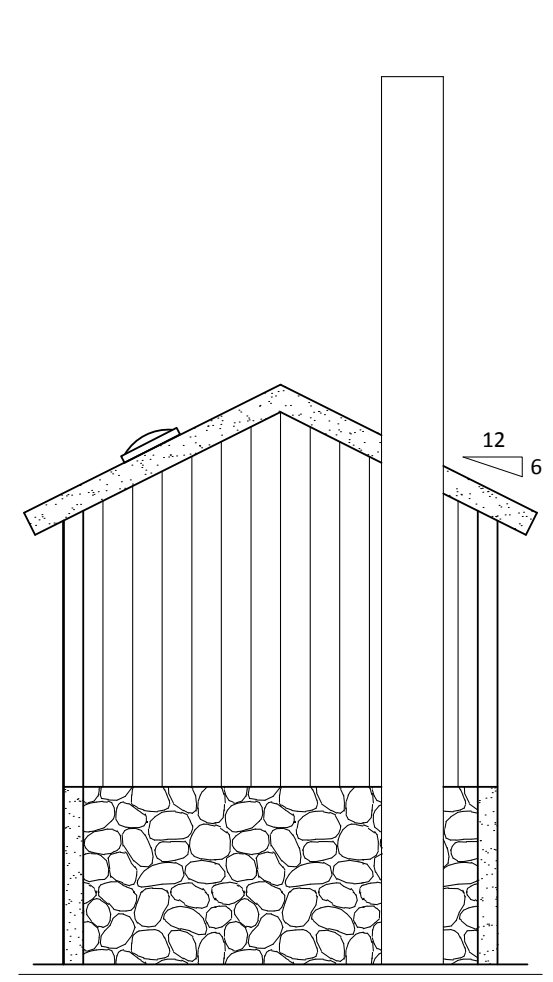

① REAR ELEVATION
SCALE: 3/8" = 1'-0"

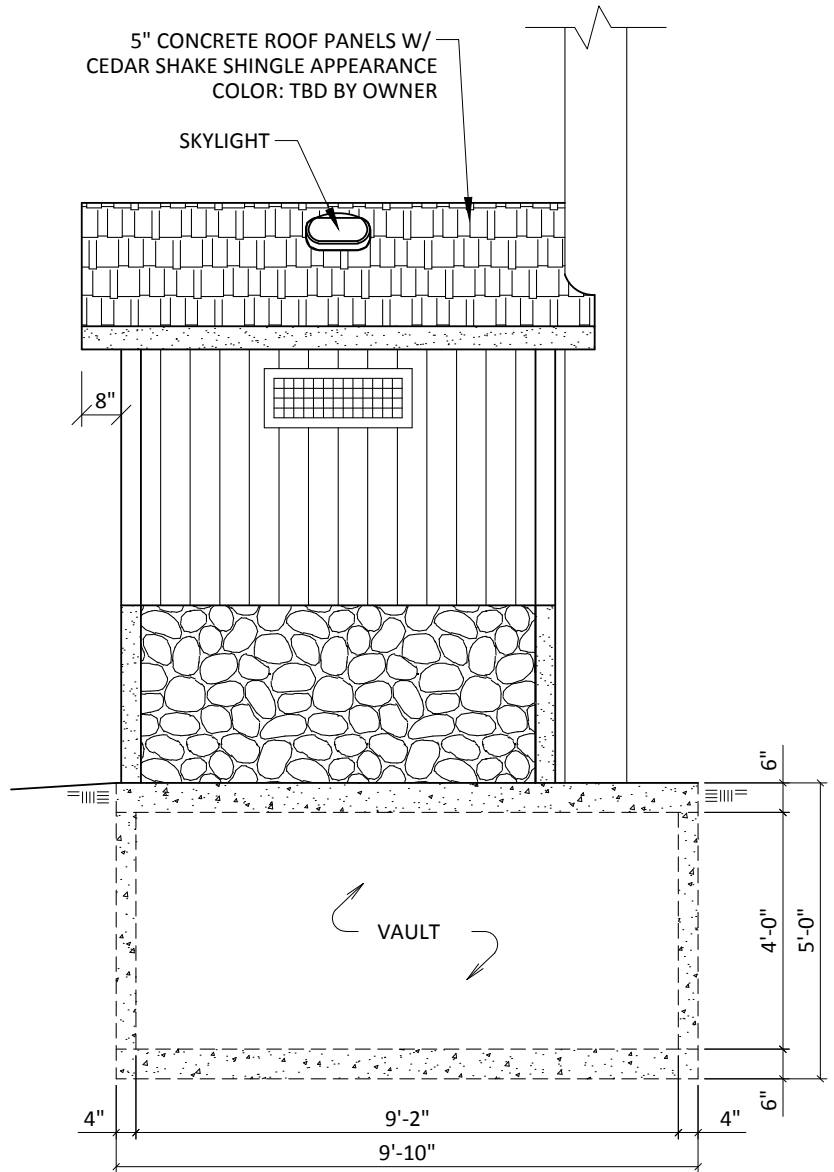

② RIGHT ELEVATION
SCALE: 3/8" = 1'-0"



Floor plans are for reference only. This drawing shall not be copied or submitted to others without the consent of this company.

4154 123rd St. Chippewa Falls, WI 54729 | 715-723-7446
HUFFCUTT.COM

SPECIFICATIONS

PART 1 – GENERAL

1. SCOPE

1.1. Construction and onsite placement of a prefabricated precast concrete vault toilet building.

2. MANUFACTURER

2.1. Manufacturer shall be Huffcutt Concrete or a pre-approved equal.

2.2. Manufacturer shall be an NPCA Certified Plant or equal with verifiable references demonstrating quality, design and service upon request.

2.3. Manufacturer will provide a written warranty providing 20 years structural, manufacturer's warranty on all hardware and components not produced at precast concrete manufacturer's plant, and 3 years against defects in paint, caulk, and grout.

3. DESIGN

3.1. Building will be manufactured using precast concrete including the roof. Building's structural design will be relevant to the region and properties associated with its final placement. Design will also meet ADA and building code requirements.

4. SUBMITTALS

4.1. Manufacturer shall provide submittals and engineering if requested.

PART 2 – PRODUCTS

1. MATERIALS

1.1. Doors and Frames

1.1.1. Doors shall be 18ga galvanized metal, louvered with 16ga frames. Doors and frames shall include one coat of rust inhibitive primer and two finish coats of enamel paint.

1.2. Door Hardware

1.2.1. Aluminum drip cap. Reese or equal.

1.2.2. Door closure with hold open. Cal-Royal or equal.

1.2.3. Stainless hinges with non-removable pin. Cal-Royal or equal.

1.2.4. Grade 1 lockset. Function and keying to be verified with owner.

1.2.5. Brush style sweep. Reese or equal.

1.2.6. ADA compliant threshold. Reese or equal.

1.3. Windows

1.3.1. Vinyl frame, bug screen and security mesh. Parco or equal.

1.4. Interior Hardware

1.4.1. Stainless 3 roll toilet paper dispensers.

1.4.2. ADA toilet stalls shall have (1) 18" stainless vertical grab bar, (1) 36" stainless horizontal grab bar, (1) 42" stainless horizontal grab bar.

1.4.3. Stainless floor mounted urinal.

1.4.4. Plastic handicap toilet riser. Romtec or equal.

1.5. Vent Pipes

1.5.1. Vent pipes shall be 12" and made of HDPE. Vent pipe shall extend approximately 36" above the roof line.

1.6. Access/Clean Out Hatch

1.6.1. Access/clean out hatch shall have a 24" x 24" clear opening, made from aluminum and be rated for a 300 psf pedestrian load. Cover shall be hinged with a kickstand to prevent accidental closing. Cover shall include a slam lock with T handle for locking.

1.7. Sealers

1.7.1. Floor shall be sealed using a deep penetrating, high alkali resistant, low volatility product. TK-290 or equal.

1.8. Caulks and Grout

1.8.1. All joints between precast panels shall be caulked using a durable, flexible polyurethane sealant. BASF Sonolastic NP-1 or equal.

1.8.2. Weld plate panel connections shall be grouted flush with interior wall surface. Speed Crete Red Line or equal.

1.9. Vault

1.9.1. Vault shall be lined with a factory installed membrane. MEL-ROL LM or equal.

2. FINISHES

2.1. Interior

2.1.1. Smooth trowel finish.

2.2. Exterior

2.2.1. Exterior wall appearance to be approved by owner using an architectural form liner.

2.2.2. Roof shall be cedar shake architectural form liner.

2.3. Paint

2.3.1. Interior

2.3.1.1. Wall panels shall be primed with a premium quality water based acrylic bonding primer moisture and alkali resistant. Finish coat shall be a high performance acrylic enamel.

2.3.2. Exterior

2.3.2.1. Roof shall be covered with a quality 100% acrylic satin paint. Owner to determine color.

2.3.2.2. Walls shall be covered with a quality concrete stain. Owner to determine color.

2.3.2.3. Doors shall be covered using 2 coats of a high performance 100% acrylic satin enamel. Owner to determine color.

Part 3 – Execution

1. PRECAST CONCRETE VAULT TOILET BUILDING

1.1. Building manufacturer shall construct, assemble, and paint at their plant so that it may be transported to the jobsite as a finished module and placed using a crane.

2. ONSITE

2.1. Contractor shall provide adequate access and a level pad for the crane and semis to sit side by side under their own power. Working radius shall be 35' from center pin on crane.

2.2. Contractor shall provide all excavation, backfilling, and finish grading for vault toilet building. In addition contractor shall provide suitable bedding of sand or granular material for the vault.

2.3. Manufacturer will install HDPE vent pipes and perform any shipping and handling adjustments and repairs.





4033 123RD STREET
 CHIPPEWA FALLS WI 54729
 715-723-7446

Quote

Order# : 10603

Date: 07/01/2024

Billed To: COD SALE

Project: CWOCC TEAL VAULT TOILET

This quote is valid for 30 days

Purchase Order#:

Description	Quantity	Price	Ext Price
TEAL VAULT TOILET	1.00	\$16,350.00	\$16,350.00
Delivery & Setting	1.00	\$3,200.00	\$3,200.00

Taxable Amount:	0.00
Sales Tax:	0.00
Quote Total	19,550.00

Taxes:

All applicable Federal, State and local taxes will be added to these prices.

Bid and Performance Bonds:

this quote does not include any bid or performance bonds. If either are required they will be added to the quote.

Professional Services/Certifications:

Architectural, structural or MEP calculations and/or stamps are not included unless specified on this quote. This quote also does not include any state manufacturer certifications/insignias. Please call for a quote if needed.

Payment Terms:

30% down payment at time of order. 30% payment at time of shipping. Balance net 30 days after invoice at time of shipment. Interest at 1.5% per month after 30 days from date of invoice unless prior arrangements have been made. Under no circumstances can retainage be held by customer.

Quotation Term:

This offer is good for 30 days from date of this quotation. Prices subject to change without notice after 30 days.

Storage:

If delivery is delayed more than 30 days after product is ready to ship, an invoice will be submitted for payment and subject to the terms above. After 60 days of storage a fee may be assessed at a rate of 1% of the total invoice per month until delivery.

Responsibilities of the Owner/General Contractor:

All excavation, elevations and permits will be the responsibility of the contractor or purchasing party.

Contractor is responsible for providing clear access for the crane and semis under their own power. These vehicles can weigh in excess of 100,000#. Clear access requires sufficient turning and maneuvering radius, suitable soil or provided alternatives to support these vehicles under their own power and free of overhead obstacles (including power lines). Additional charges may be assessed if reasonable means are not provided.

Working radius of the crane will be 35' or less with the semi sitting next to the crane. Additional charges will apply if a larger working radius is required. Crane rental may be provided by others.

Owner/General Contractor are responsible for providing a suitable foundation for the building. We can provide you with the weight of the building. Frost walls or grade beam are acceptable but you will need to determine your soil conditions and State/Local building codes.

It is the responsibility of the owner/contractor to comply with any building codes, permits and special requirements. Huffcutt Concrete, LLC can incorporate any special requirements into your building as said owner/general contractor informs Huffcutt Concrete, LLC prior to building being manufactured. Some special requirements may incur an additional charge.

Owner/General Contractor will be responsible for roughing in the plumbing supply lines, waste line, electrical, floor drains and plumbing vent lines. Huffcutt Concrete, LLC will provide you with a mechanical rough in drawing.

During the installation the contractor or owner will provide site personnel who are knowledgeable, has the authority to make decisions and resources available to make changes if necessary. Prior to setting of the building, Huffcutt Concrete, LLC will verify the foundation to be level within 1/4" and mechanical rough in locations are accurate. After the building is set Huffcutt Concrete, LLC will perform the final caulking, ridge cap, paint touch up and shipping and handling adjustments and repair. Owner/General Contractor will be responsible for the final onsite mechanical connections in the building. These include, but not limited to water supply line, waste lines, plumbing vent lines, electrical connection to the service panel and any tightening of fittings that may have loosened during shipping and handling.



New / Expanded Position Request Form

Department: Solid Waste **Requested by:** David Hagenbucher

Nature of Request (mark one)

Create/Add a position(s) in the department **Number of Positions:** 1

Create and abolish a current position

Expand/change FTE of a current position

Current FTE: Click or tap here to enter text. New FTE: Click or tap here to enter text.

Other: Click or tap here to enter text.

Classification Title/Working Title Pay Grade (OLD): Click or tap here to enter text.

Classification Title/Working Title Pay Grade (NEW): Waste Management Specialist

Attach: Job description of requested position **-OR-** Position Description Questionnaire (PDQ)

Summarize the major functions of the proposed position: The Environmental Management Specialist (EMS) is responsible for assisting with the daily operations of the Solid Waste Gas Collection and Control System and flare embedded within the 3 landfills on site serving customers and communities throughout Central and North-Central Wisconsin. The Environmental Management Specialist works directly with MCSWD operations staff to manage the sanitary landfill system that contains waste from multiple regional partners and customers. The EMS is responsible for all field work associated with landfill gas monitoring and maintenance for delivery to flare or landfill gas energy recovery, including renewable natural gas processing. EMS will perform frequent monitoring and adjustments of 70+ LFG wellheads and multiple future LFG wellhead additions, to adhere to strict state and federal guidelines, while being conscious of the local environmental impacts of landfill gas recovery. The EMS is responsible for maximizing landfill gas volume while meeting strict concentration targets for gas quality. Work will also minimize environmental contamination by leachate and gas condensate liquids, which are direct possible contaminants to the local air and ground water supply. Inability to operate any part of the GCCS can have a direct effect on the environment and the Solid Waste Budget.

Please indicate: FT or PT

Hours per pay period: 40

Start Date: 2025 Budget Year **-OR-** Projected Start Date: Jan 1 2025 (OR RNG STARTUP)

Reason for Request/Justification:

(Reason for the new position or expanded FTE. Describe the need for this position including the benefit to the department/county if this position is filled and the negative impact if not filled.)

The Environmental Management Specialist is responsible for ensuring that protection of human health and the environment is the absolute highest priority. This position works in conjunction with the Operations Manager, the Environmental Systems and Pollution Control Specialist, the Renewable Natural Gas Facility, the State of Wisconsin regulatory agency, and multiple engineering firms on gathering, tracking, logging, and analyzing critical information needed to keep the environment safe and ensure efficiency of the gas collection operation. **Marathon County is contractually obligated to ensure that all commercially available means for gas collection are being done to maximize volume, while also ensuring that concentration targets are achieved.** The decisions and daily tasks that this position is responsible for are monumental in they greatly impact the department's budget, as well as the health and safety of the entire County. Moreover, this position will be responsible for ensuring that Marathon County is getting the best value for their efforts relative to



New / Expanded Position Request Form

Renewable Natural Gas. The position will create bench strength and deliver on our commitment to capture landfill gas and meet quality targets. If successful, the entire County will benefit from the associated gas royalties. Furthermore, keeping the air and water clean are not only essential to sustaining life, but also mandated by State and Federal law. With the leadership, problem solving abilities, and field skills of this position, there will be significant opportunity to enhance landfill operations and assist in sustaining the Department for long term service to our community. Solid Waste success depends heavily on the abilities of this professional to perform the work.

COSTING: What is the anticipated total cost of this position: \$75,000 - \$100,000

(Include salary; benefits; office space, remodeling, furniture, and equipment; travel; and other applicable costs. If you need assistance in calculating cost, contact Employee Resource for salary and benefits.)

Please list additional costs anticipated: Click or tap here to enter text.

FUNDING: Please explain how the position will be funded:

County tax levy: Click or tap here to enter text. % Of total costs: Click or tap here to enter text.

Outside funding: Solid Waste Department Fund – Gas Royalty % Of total costs: 100

Source and length of outside funding: 30 Years

Will this request require NEW funding in 2025 or current year?

YES, take to Committee of Jurisdiction / HR Finance Committee / County Board-
Annual Fiscal Impact (full year): Click or tap here to enter text.

If midyear: Estimated cost for remainder of 2024: Click or tap here to enter text.

******Requestor should prepare Resolution Draft to share with Committees at this time.**

NO Request may be taken to committee before 2025 Budget Process.
Discuss with Employee Resource Director and County Administrator.

Please attach any additional supporting documentation such as full job description, costing, or proposed change to organization chart.

Requested by: David Hagenbucher

Date: July 8 2024

Department Approval: Click or tap here to enter text.

Date: Click or tap here to enter text.

Completed request should be forwarded to Employee Resources: Molly Adzic, Boly Vang and Sue Fox

ENVIRONMENTAL MANAGEMENT SPECIALIST –FTE 2025

Exhibit E of the January 23rd, 2023 Landfill Gas Purchase Agreement

GAS QUALITY

Gas Quality Targets

Methane Content	54% or More CH ₄ by volume
Oxygen Content	Less than 0.5% by volume
Nitrogen Content	Less than 5% by volume

Gas Quality Limits

Minimum Methane Content	50% CH ₄ by volume
Maximum Oxygen Content	1.2% by volume
Maximum Nitrogen Content	10% by volume

Section 5.1 of the January 23rd, 2023 Landfill Gas Purchase Agreement

environmental laws and regulations. Seller will use its best efforts to maximize the amount of Landfill Gas collected for use by Purchaser. Best efforts shall be defined as gas collection methods generally accepted in the solid waste industry. Additionally, the Seller agrees to use best efforts to work cooperatively with Purchaser to allow for coordinated communications and operations between the Seller's Facilities and the Purchaser's Facilities intended to meet the objectives of maintaining Landfill compliance with federal, state, local regulations, and applicable permits, as well as balance Purchaser's desire to maximize the quantity, quality and availability of LFG to Purchaser's Facilities with the health of the Landfill and Seller's contractual obligations. These