

# Highway Department Policies and Procedures Manual

**Marathon County, Wisconsin**



**Adopted by the Marathon County Infrastructure Committee  
Originally Adopted November 2007  
Revised December 2017**

Originally Prepared by  
URS Corporation





## TABLE OF CONTENTS

<p>ACRONYMS..... v</p> <p><b>Introduction ..... 1</b></p> <p style="padding-left: 20px;">Purpose of the Manual ..... 1</p> <p style="padding-left: 20px;">General Maintenance Activities ..... 1</p> <p style="padding-left: 20px;">Marathon County Infrastructure Committee ..... 3</p> <p style="padding-left: 20px;">Highway Commissioner ..... 3</p> <p style="padding-left: 20px;">Highway Department Contact Information..... 3</p> <p style="padding-left: 20px;">Frequently Asked Questions ..... 4</p> <p><b>County Trunk Highway System ..... 6</b></p> <p style="padding-left: 20px;">Purpose ..... 6</p> <p style="padding-left: 20px;">Jurisdiction ..... 6</p> <p style="padding-left: 20px;">Functional Classification..... 6</p> <p style="padding-left: 20px;">Accessibility vs. Mobility..... 7</p> <p style="padding-left: 20px;">Rural vs. Urban ..... 8</p> <p><b>Driveway Permits ..... 10</b></p> <p style="padding-left: 20px;">Purpose ..... 10</p> <p style="padding-left: 20px;">Guidelines ..... 10</p> <p style="padding-left: 20px;">Maintenance ..... 11</p> <p style="padding-left: 20px;">Driveway Surfacing ..... 11</p> <p style="padding-left: 20px;">Culverts ..... 11</p> <p style="padding-left: 20px;">Appeal Process ..... 11</p> <p><b>Public Right-of-Way ..... 14</b></p>	<p style="padding-left: 20px;">Purpose ..... 14</p> <p style="padding-left: 20px;">County Highway Right-of-Way..... 14</p> <p style="padding-left: 20px;">Public Utilities ..... 14</p> <p style="padding-left: 20px;">Private Property ..... 14</p> <p style="padding-left: 20px;">Right-of-Way Encroachments ..... 15</p> <p style="padding-left: 20px;">Memorials..... 15</p> <p style="padding-left: 20px;">Refuse Containers..... 17</p> <p style="padding-left: 20px;">Manure Pipelines..... 17</p> <p style="padding-left: 20px;">Mailboxes ..... 18</p> <p style="padding-left: 20px;">Plantings, Crops, and Other Vegetation..... 21</p> <p style="padding-left: 20px;">Trees ..... 23</p> <p style="padding-left: 20px;">Fences and Other Structures ..... 23</p> <p style="padding-left: 20px;">Headwall Structures ..... 24</p> <p style="padding-left: 20px;">Driveway Approaches ..... 24</p> <p><b>Vision Clearance Triangle ..... 28</b></p> <p style="padding-left: 20px;">Purpose ..... 28</p> <p style="padding-left: 20px;">Standards ..... 28</p> <p style="padding-left: 20px;">Highway Setbacks ..... 31</p> <p style="padding-left: 20px;">Reduced Building Setbacks ..... 32</p> <p><b>Utility Accommodations ..... 33</b></p> <p style="padding-left: 20px;">Purpose ..... 33</p> <p style="padding-left: 20px;">Utility Accommodations Requirements..... 33</p> <p style="padding-left: 20px;">Utility Permit ..... 33</p> <p style="padding-left: 20px;">Coordination with Planned Improvements..... 33</p> <p style="padding-left: 20px;">Preferred Utility Accommodations ..... 34</p> <p style="padding-left: 20px;">Boring and Trenching ..... 34</p> <p style="padding-left: 20px;">Open Cut Policy ..... 34</p>
---	---



Installation and Repair Requirements .....	36	Snow Removal Procedures .....	47
Prior to Beginning Work .....	36	Decision to Begin Snow Removal .....	47
On-Site Requirements .....	36	Snow Removal Methods .....	47
General Requirements .....	36	Passable Roadway.....	47
Open Cut Repair Requirements.....	37	Level of Service and Hour of Operation .....	48
Authority to Enforce Policy .....	37	Standing Corn Row Snow Fence Program .....	48
Failure to Comply.....	37	Road Conditions.....	49
<b>Road Debris and Obstructions .....</b>	<b>39</b>	Service Areas.....	49
Purpose .....	39	Snow Emergency .....	49
Debris and Obstructions .....	39	Highway Department Personnel.....	52
Litter .....	39	Damage to Private Property.....	52
Storm Debris and Obstructions .....	39	Motorists Responsibilities.....	52
Animal Removal.....	39	<b>Pavement Management .....</b>	<b>53</b>
Farm Debris .....	39	Purpose .....	53
Snow and Ice .....	40	Pavement Ratings .....	53
<b>Adopt-A-Highway Program .....</b>	<b>41</b>	Training Assistance.....	53
Purpose .....	41	“Life Cycle” Maintenance Approach .....	56
Application Process.....	41	Five-Year Needs Analysis.....	56
Approval Process .....	41	Typical Maintenance Activities.....	56
Signage .....	41	Crack Sealing .....	58
Adopt-A-Highway Program Requirements .....	42	Minor Patching .....	58
Annual Requirements .....	42	Slag / Chip Seal Coating .....	58
Age and Supervision Requirements .....	42	Mill and Overlay.....	58
Safety Requirements .....	42	Asphalt pulverizing .....	59
Transportation to the Cleanup Area.....	43	Cold In-Place Recycling .....	59
Handling the Litter.....	44	Reconstruction .....	59
<b>Snow and Ice Removal .....</b>	<b>47</b>	Lane Wedging .....	59
Purpose .....	47	Liability.....	59
		Shoulder Paving Policy .....	60
		Purpose .....	62
		Inspection Process .....	62



Visual Inspections .....	62	<b>Snowmobiles and ATVs .....</b>	<b>73</b>
Bridge Maintenance .....	62	Purpose .....	73
County Bridge Aid .....	63	Snowmobile and ATV Rules .....	73
Application Process .....	63	Snowmobile Coordinator .....	73
Policy .....	63	Snowmobile Season .....	73
Funding .....	64	Snowmobile and/or ATV Route .....	73
<i>County Bridge Aid on Federal Aid Projects</i> .....	64	Snowmobile Trail.....	73
Concurrent Action .....	64	Liability .....	74
Appeal Process .....	64	Snowmobile and ATV Use of Highways .....	74
<b>Overweight/Oversized Vehicles.....</b>	<b>66</b>	Use Along County Highways.....	76
Purpose .....	66	Highway Crossings.....	76
Single Trip Permit.....	66	Traffic Signs .....	76
Permit Requirements .....	66	Exceptions.....	76
Haul Routes .....	67	<b>Signing and Safety.....</b>	<b>78</b>
Applicant (Mover) Responsibilities .....	67	Manuals for Uniform Traffic Control Devices .....	78
Non-Compliance .....	67	Sign Requests .....	78
Manure Hauling Permits.....	68	Intersection Control.....	78
<b>Seasonal Weight Limits.....</b>	<b>68</b>	Work Zone Safety.....	81
Purpose .....	69	Safety Apparel.....	82
Milk Haulers.....	69	<b>Miscellaneous Items .....</b>	<b>83</b>
Request for All Season Road .....	69	Procurement .....	83
Wisconsin Frozen Road Law.....	70	Cooperative Agreements .....	83
<b>TODS Program .....</b>	<b>71</b>	Work for Municipalities.....	83
How Do I Get A Sign? .....	71	Brush Pick-Up.....	83
What is a TOD Sign?.....	71	Dust Control during Construction.....	83
Will My Business Qualify for a Sign?.....	71	Vegetation .....	83
Additional Rules Include:.....	71	Noxious Weeds .....	83
How Much Does The Sign Cost? .....	72	Marathon County Invasive Species BMPs.....	84



Vegetation management & Inspection/Monitoring BMPs.... 84  
 Soil Disturbing Activities and Moving of Materials..... 84  
 Disclaimer..... 84  
 Miscellaneous Transportation Related Links..... 85  
 List of Wisconsin Statutes and Administrative Rules..... 86

**Appendix A ..... 1**  
 Introduction..... 1  
 Overview of Asset Management.....2  
 Pavement Management Program (PMP).....3  
 Bridge Management Program (BMP) .....9  
 Project Prioritization ..... 14

**Appendix B ..... 15**  
 Introduction..... 16  
 Implementation Plan..... 16  
 Implementation of a PMP ..... 16  
 Implementation of a BMP ..... 17

**LIST OF FIGURES**

Figure 1. State and County Highway System .....2  
 Figure 2. Mobility vs. Accessibility ..... 7  
 Figure 3. County Highways – Rural vs. Urban Areas .....9  
 Figure 4. Highway Access / Driveway Policy ..... 12  
 Figure 5. Typical Maintenance Limits for County Highway Intersections with Side Road and Driveways..... 13  
 Figure 6. Public Right-of-Way ..... 16  
 Figure 7. Proper Mailbox Installation .....20

Figure 8. Plantings, Crops and Other Vegetation .....22  
 Figure 9. Tree Care Responsibility.....25  
 Figure 10. Proper Fence Installation .....26  
 Figure 11. Proper Headwall Installation .....27  
 Figure 12. Typical Vision Triangle .....29  
 Figure 13. Open Cut Utility Permit Fees .....35  
 Figure 14. Parking at the Roadside Cleanup Area.....45  
 Figure 15. Roadside Cleanup Area .....46  
 Figure 16. Snowplow Route (State Roads).....50  
 Figure 17. Snowplow Routes (County Roads) .....51  
 Figure 18. Pavement Condition Rations (10 to 6) .....54  
 Figure 19. Pavement Condition Ratings (5 to 1).....54  
 Figure 20. Typical Pavement Maintenance.....57  
 Figure 21. Bridge Sufficiency Ratings .....65  
 Figure 22. Highway / Trail Crossings .....77  
 Figure 23. Rumble Strip Layout .....80  
 Figure 24. Rumble Strip Layout (Thermoplastic) .....81



**ACRONYMS**

<b>ADT</b>	Average Daily Traffic count	<b>PPE</b>	Personal Protective Equipment
<b>Ag CMV</b>	Agricultural Commercial Motor Vehicle	<b>PSC</b>	Public Service Commission
<b>ANSI/ISEA</b>	American National Standards Institute & International Safety Equipment Association	<b>PS &amp; E</b>	Plan, Specifications and Estimate
<b>ATV</b>	All Terrain Vehicles	<b>ROW</b>	Right-of-Way
<b>BIA</b>	Bureau of Indian Affairs	<b>§</b>	State Statute (Section or Chapter)
<b>BMP</b>	Best Management Practices	<b>STH</b>	State Trunk Highway
<b>CHI</b>	County Highway Improvement Program (formerly CHIP)	<b>STP-R</b>	Surface Transportation Program - Rural
<b>CTH</b>	County Trunk Highway	<b>STP-U</b>	Surface Transportation Program - Urban
<b>DNR</b>	Department of Natural Resources	<b>TRI</b>	Town Road Improvement Program (formerly TRIP)
<b>FDM</b>	Facilities Development Manual	<b>USH</b>	United States Highway
<b>I or IH</b>	Interstate Highway	<b>WCHA</b>	Wisconsin County Highway Association
<b>IoH</b>	Implement of Husbandry	<b>WisDOT</b>	Wisconsin Department of Transportation
<b>LFA</b>	Local Force Account	<b>WISLR</b>	Wisconsin Information System for Local Roads
<b>MSIP</b>	Municipal Street Improvement Program	<b>VCT</b>	Vision Clearance Triangle
<b>MUTCD</b>	Manual for Uniform Traffic Control Devices		
<b>NBI</b>	National Bridge Institute		
<b>PASER</b>	Pavement Surface Evaluation and Rating		







## Introduction

The Marathon County Highway Department operates the highway system under its jurisdiction to provide a safe and convenient means for the vehicular transportation of people and goods. The department oversees the maintenance of over 600 miles of the county trunk highway system and annually contracts with the Wisconsin Department of Transportation (WisDOT) to maintain over an additional 700 lane miles of State and Federal Highway System roads (see **Figure 1**). The Highway Department also provides technical assistance, financial aid, and various services to other local units of government. These services are critical to maintaining a safe, convenient, and efficient transportation system serving communities, residents, and businesses throughout Marathon County.

### ***Purpose of the Manual***

The purpose of this manual is to outline specific transportation policies and procedures as they relate to the Marathon County Highway Department. The manual is intended to provide important information to the general public and to serve as an internal manual providing clear direction to department staff and decision makers.

### ***General Maintenance Activities***

The Marathon County Highway Department is responsible for the maintenance of county highways and state roads through contract with WisDOT. The general maintenance consists of all activities aimed at keeping the system in a serviceable condition. This includes, but is not limited to: pothole repairs, mowing, centerline painting, culvert replacement, ditching, wheel rut repairs, minor overlays, signing and litter control.

A primary concern is to maintain a safe and drivable pavement while protecting the County's investment in quality roads. When necessary, the Highway Department will reconstruct or resurface roadway segments that do not meet current design standards. Additional improvements may include widening the pavement and shoulders, flattening ditch in-slopes, flattening horizontal curves, improving or increasing sight distance, and drainage improvements.

### **Mission Statement**

*The Marathon County Highway Department  
will strive to maintain all State and County  
highways in a safe and  
reasonable condition  
at all times.*

Figure 1. State and County Highway System

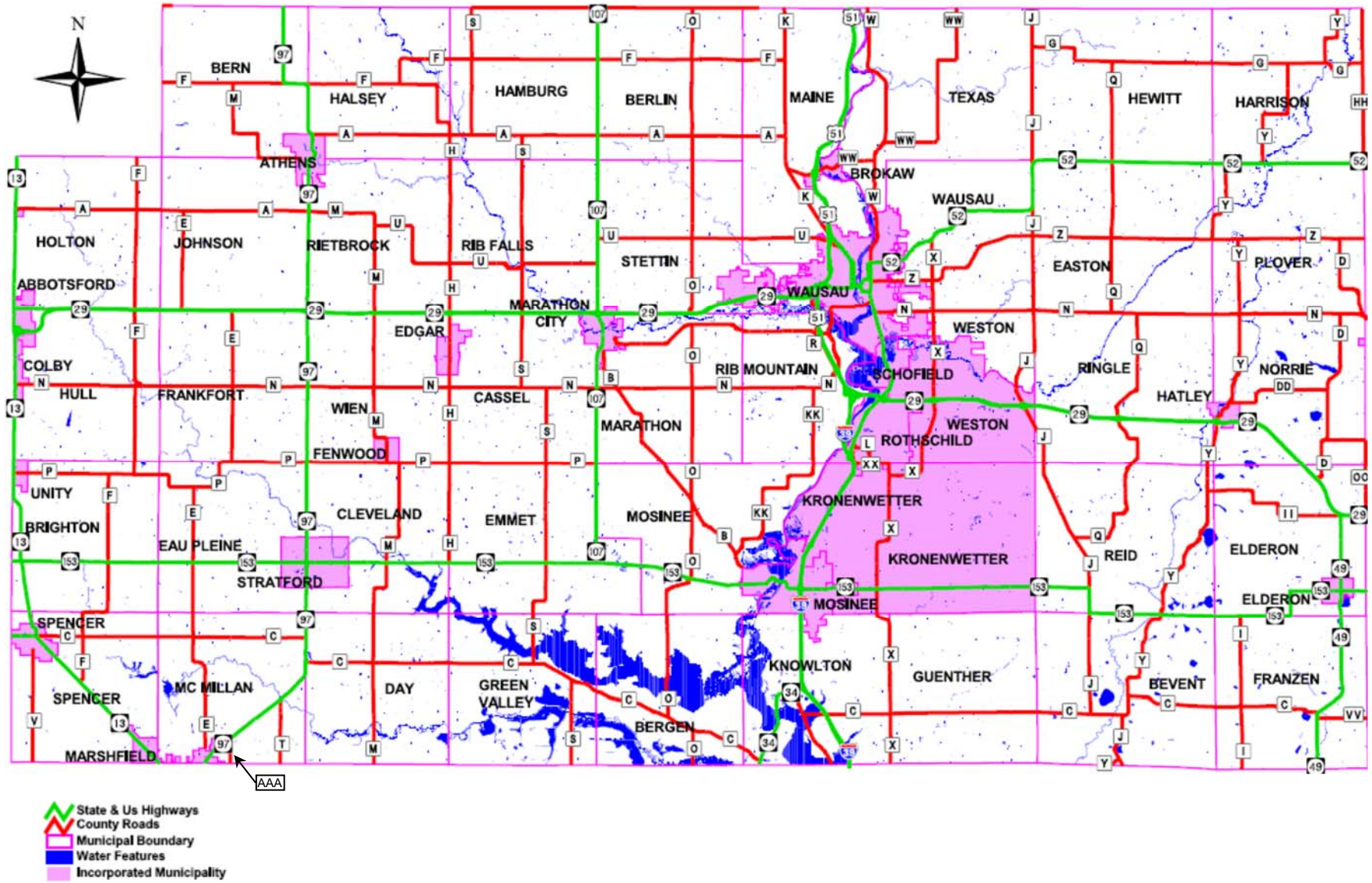



## **Marathon County Infrastructure Committee**

A seven member Infrastructure Committee, appointed by the County Board Chair, establishes the policies by which the Highway Commissioner or designee will operate the Highway Department actions (Wisconsin Statute 80.15(b) and Marathon County Ordinance Section 2.04).

The Infrastructure Committee establishes and reviews policies and procedures on:

1. Access to county highways and use of county highways for special events (bikathons, parades, etc.).
2. Performing work for other municipal agencies (towns, villages, state or other county departments).
3. Purchasing procedures and items purchased (subject to Marathon County Procurement Code).
4. How County highways are selected for rehabilitation using uniform and unbiased procedures.
5. Providing opportunities for the public to be heard concerning operation of the Highway Department.

The Infrastructure Committee also oversees all summer road repairs, reconstruction and maintenance of roads and bridges, and winter work which primarily includes snow removal and other winter maintenance activities.

## **Highway Commissioner**

The Marathon County Highway Department is led by the Highway Commissioner. The Highway Commissioner is in charge of all maintenance and construction work on the County Trunk Highway System as well as maintenance, under contract with the state, of the State highways in the county.

## **Highway Department Contact Information**

To report problems regarding a county road or to submit general concerns or comments, please use the following:

### **Mail**

1430 West Street  
Wausau, Wisconsin 54401

### **Phone**

715-261-1800

### **Fax**

715-261-1810

### **Internet**

Visit the Marathon County Highway Department website at

[www.co.marathon.wi.us/highway.asp](http://www.co.marathon.wi.us/highway.asp)



## **Frequently Asked Questions**

The following are some frequently asked questions that relate to Marathon County Highway Department services. Additional information regarding these questions can be found in this manual.

### **I noticed a dead animal on the road, who do I contact?**

Dead animals on the roadway may create a potential hazard to the traveling public. If a large dead animal (i.e., deer, a large dog, etc.) is lying on the roadway please contact the appropriate highway authority that has jurisdiction of that road (for example, County, City, Village, or Township). If it is a County maintained highway please contact the Marathon County Highway Department at (715) 261-1800.

### **How do I find out where the right-of-way is located on my property?**

If you are unsure of exactly where the right-of-way line is for your property, please contact the appropriate highway authority. Before doing anything within the right-of-way, it is important that you contact the Highway Department for approval. Additional information regarding the right-of-way issues is also provided in this manual (see **Figure 5**). Please note that the Marathon County Highway Department does not locate property lines. The property owner should call a surveyor to locate property lines.

### **Do I need a permit to construct a new driveway / access point to a County Highway?**

Wisconsin law requires property owners to acquire a driveway/access permit prior to constructing a new access point connecting to the County Trunk Highway System. You should contact the Marathon County Highway Department for specific details on obtaining a permit.

### **Does the Highway Department provide dust control on Town roads that motorists use as a detour or alternate route around County Highways that are under construction?**

The Department does not normally provide dust control. If a County Highway is required to have a **signed detour on a Town Road** for a project lasting 4 days or more, the Department will evaluate the need for providing dust control.

### **Who do I notify if there is a road hazard on or along a county road?**

Hazardous conditions may develop on county roads for a number of reasons. Storms may cause trees or limbs to fall onto the roadway while heavy rain may result in flooding at isolated highway locations. Potential hazards may result from debris falling off of trucks or other vehicles. If a potentially hazardous condition exists on a road you should contact the Sheriff's Department at (715) 261-1200. The Sheriff's Department will in turn notify the appropriate Highway Department personnel to remove the hazard.



**My property (mailbox, fence, etc.) was damaged by a snowplow, who should I contact?**

You should contact the Marathon County Highway Department at (715) 261-1818. If it is determined that the mailbox was damaged by actual physical contact by a County snowplow then the mailbox will be replaced by the Highway Department. If the mailbox is damaged due to snow plowing, and not actual physical contact with a County snowplow, the mailbox replacement and costs are the responsibility of the property owner. Before calling, it may be helpful to review the following to determine if the Highway Department may be responsible for the property damage.

**The County may be responsible for the following:**

- If it is shown that a piece of County snow removal equipment has caused damage by actual physical contact with a mailbox, the Highway Department will repair or replace the damaged mailbox. If a replacement mailbox is needed, the Highway Department will provide and install a standard, #1 size conventional mailbox (approximately 7" x 9" x 18") and/or support.
- If it is shown that a piece of County snow removal equipment has caused damage by actual physical contact with a fence or other structure, the Highway Department will review the incident on a case-by-case basis to determine what, if any, responsibility that the Highway Department has to repair the damage. Property owners are reminded that the Highway Department will not be responsible for damage, even if caused by actual physical contact, that occurs to structures that have been improperly located within the public right-of-way (please refer to **Public Right-of-Way** section of this manual for additional details).

**The County is not responsible for the following:**

- Damage that is caused to a mailbox, or other properly located structures outside the public right-of-way, as a result of plowed snow or the force of snow being discharged by County snow removal equipment.
- Damage that is caused to any fences, headwalls, trees, shrubs, plantings, and other structures that are improperly located within the public right-of-way (please refer to **Public Right-of-Way** section of this manual for additional details).
- Damage that is caused to lawns or for the deposition of gravel in road ditches. If there are extenuating circumstances, these situations may be reviewed at the County's discretion on a case-by-case basis. Any vegetation damage sustained due to de-icing products used on the roadway will not be treated or repaired by the County.
- Damage to abandoned vehicles that have been left on the County Highway. If the Highway Department personnel come upon an abandoned vehicle, they will contact the Sheriff's Department to request the vehicle to be removed at the owner's expense. If a vehicle is blocking one or more lanes halting snow and ice control operations, the Highway Department has the authority to move the vehicle by whatever means are necessary to reopen the roadway. Any damage incurred in such a move shall be the owner's responsibility.



## County Trunk Highway System

The County Trunk Highway System, established in 1925, forms the secondary system of highways within the state and constitutes the interconnecting highways supplementing the State Trunk Highway System. It is comprised mainly of highways of secondary through-traffic importance and generally consists of highways that provide and facilitate local service. The County Trunk Highway System is administered by the Marathon County Highway Department as authorized under Section 83 of the Wisconsin Statutes.

The County Trunk Highway System includes all highways that have been selected by the Marathon County Board and approved by WisDOT in accordance with Section 83.025 of the Wisconsin Statutes. County highways are designated alphabetically and the marking and signing is uniform throughout the state. Improvements or construction of highways on the County Trunk Highway System must conform to minimum geometric design standards established in Trans. 205 of the Wisconsin Administrative Code and Chapter 11 of the Wisconsin Facilities Development Manual.

### **Purpose**

County Trunk Highways are meant to provide a high level of mobility to the traveling public. County Trunk Highways have historically provided farm to market routes and connect cities and villages to higher level state highways. Highways within urbanized areas will have high levels of access control to ensure they meet the requirement of providing mobility with a minimum number of access points. Roads providing primary

access to commercial areas and residential areas should be located on the local road system.

### **Jurisdiction**

Highways are commonly classified by ownership or purpose. Jurisdictional responsibility refers to governmental ownership of a particular road; however, governmental ownership does not necessarily reflect who is responsible for the on-going maintenance of the facility. For example, State owned roads are maintained by the Marathon County Highway Department or local jurisdictions through contract with WisDOT. The Highway Department is responsible for conducting routine maintenance and minor repairs on state and federal highways. However, major repairs and reconstruction are generally still the responsibility of the WisDOT.

### **Functional Classification**

Functional classification is a process by which streets and highways are grouped into classes according to the character of service they provide, ranging from a high degree of travel mobility to land access functions. Federal regulations require that each state classify roadways in accordance with the Federal Highway Administration's Highway Functional Classification: Concepts, Criteria and Procedures. The functional classification hierarchy is generally defined as:

- **Principal Arterials** serve corridor movements having trip lengths and travel density characteristics of an interstate or interregional nature. These routes generally serve all urban areas with populations greater than 5,000 or connect major centers of activity.



- **Minor Arterials**, like principal arterials, serve cities, large communities, and other major traffic generators providing intra-community continuity and service to trips of moderate length, with more emphasis on land access than principal arterials.
- **Collectors** provide both land access service and traffic circulation within residential neighborhoods, commercial areas, and industrial areas. The collector system distributes trips from the arterials through the area to the local streets.
- **Local Streets** comprise all facilities not on one of the higher systems. Local streets provide direct access to abutting land and access to the higher order of systems. Local streets offer the lowest level of mobility, and through-traffic movement on this system is generally discouraged.

It is the policy of the Marathon County Highway Department to review the County Trunk Highway System on a bi-annual basis to ensure that the roadways are serving their intended purpose (i.e., mobility or accessibility). The primary criteria for defining County Trunk Highways includes functional classification, average daily traffic (ADT) volumes, posted and observed travel speeds, and access control.

**Accessibility vs. Mobility**

A highway network serves a dual role in providing (1) access to property, and (2) travel mobility. Access is a fixed requirement, necessary at both ends of any trip. Mobility, along the path of such trips, can be provided at varying levels, usually referred to as "level of service." It can incorporate a wide range of elements

(e.g., riding comfort and freedom from speed changes) but the most basic is operating speed or trip travel time.

The functional classification of a roadway dictates the general level of accessibility vs. mobility (see **Figure 2**). At the upper limit of the system (e.g., principal arterials) are those facilities that emphasize traffic mobility (long, uninterrupted travel), whereas facilities at the lower limits (e.g., local roads) are designed to emphasize land access. Collectors offer a compromise or transition between both functions.

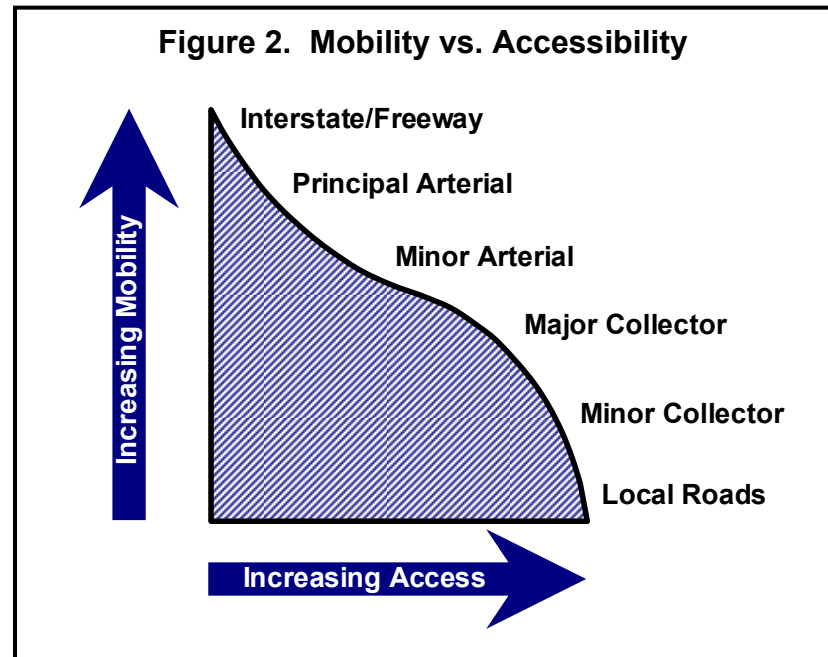



### **Rural vs. Urban**

The County Trunk Highway System connects cities, towns, and villages, often located in rural areas, to larger urban areas, or other major trip centers. **Figure 3** displays a schematic illustration of a functionally classified rural and urban roadway network. How the County Trunk Highway System is intended to function within rural and urban areas is discussed in the following.

In the rural area, larger cities are generally connected via arterial highways that provide direct service between the urban areas. These arterials are generally State or County owned and the Marathon County Highway Department is likely responsible for the maintenance of these roads, directly for County roads or through contract with WisDOT for State roads. The collector roadways in rural areas generally serve small towns and villages directly, connecting them to the arterial network. The collectors, generally speaking, gather traffic from the local roads, the lowest functionally classified roads which serve individual residences, farms, and other rural land uses.

The same basic concepts apply within an urban area; however, because of higher intensity and varying land uses other considerations, such as access locations and spacing, ADT volumes, posted and observed travel speeds, and traffic control devices become even more important in defining a logical and efficient County Trunk Highway System. It is not uncommon for a State or County highway to pass through an urban area. In fact, this is necessary for the County Trunk Highway System to function properly and ultimately accomplish its primary purpose of connecting cities and villages. When a County Trunk Highway passes through an urban area it is critical that this facility provides a high level of access control to ensure that it is meeting the primary purpose of providing mobility with a

minimum number of access points. When a segment of the County Trunk Highway System is no longer serving this purpose, it may be appropriate to evaluate the highway corridor, or segment in question, to determine what actions might be necessary to ensure that the facility serves the intended purpose.

As displayed in **Figure 3**, the principal arterial (State or County) in the urban area should have limited access generally connecting to minor arterials (local municipality) or collector streets. The minor arterials and collector streets in turn provide increasing levels of accessibility to commercial, office, and industrial land uses. The collector roads also provide the primary connection to local streets which provide direct access to neighborhoods and residential areas. Generally speaking, roadways serving a local function should be the local jurisdiction's responsibility and roadways serving a more regional function should be the responsibility of the State or County.



Figure 3. County Highways – Rural vs. Urban Areas

**Rural Area**

**Urban Area**

Arterial roads within a rural area are likely state or county owned and are meant to provide a high level of mobility to the traveling public connecting cities and villages.

Access to a commercial or office area is best served by a municipalities collector road, or minor arterial, as opposed to direct access from a state or county highway (principal arterial)

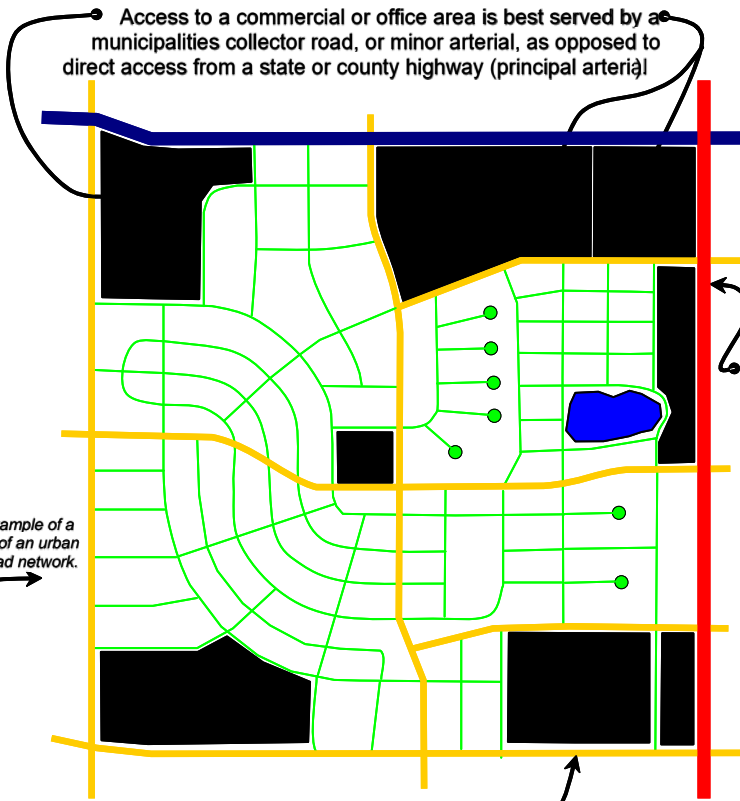
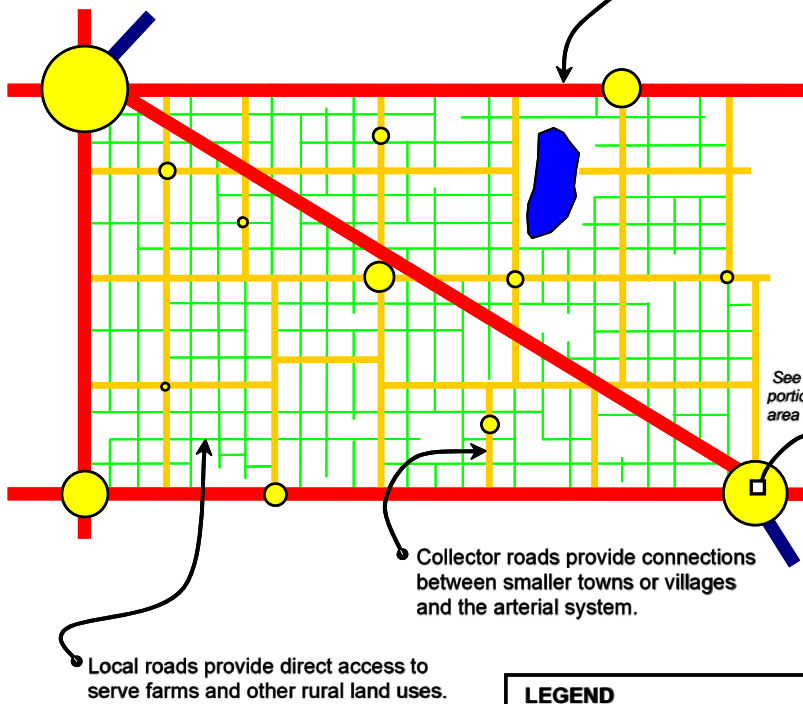

A state or county highway (arterial) often pass through an urban area but these facilities should have high levels of access control to ensure they meet their primary purpose of providing mobility with a minimum number of access points.

Local roads provide direct access to serve farms and other rural land uses.

Collector roads provide connections between smaller towns or villages and the arterial system.

See example of a portion of an urban area road network.

Collector roads within an urban area

Collector roads within an urban area are generally the responsibility of the local municipality and are intended to serve both access and mobility functions.

NOTE: Schematic Drawing..Not to Scale.

**LEGEND**

	Arterial (State or County Highway)		Urban Area (City, Town, or Village)
	Arterial (Local Municipality)		
	Collector		
	Local Street		School
			Commercial
			Office
			Park / Open Space



## Driveway Permits

Wisconsin law requires a written permit to refill or install a driveway or culvert. Driveway permits are issued by officials of the Marathon County Highway Department and are required for all residential and commercial access onto a county highway.

### Purpose

The review of driveway permits helps improve the design and placement of driveways, medians, and other access control measures. The overall goal is to eliminate or limit potential traffic conflicts and ultimately increase safety. The proper placement and spacing of driveways can also improve traffic flow by reducing potential conflict points.

### Guidelines

The Marathon County Highway Department uses the following guidelines in reviewing driveway/access onto the County Trunk Highway System. **Figure 4** displays an example of the guidelines. Meeting the Guidelines does not guarantee access will be granted. Consideration will be given to the impact the access will have on the traveling public.

1. **Stopping Sight Distance** – Drivers traveling at 55 mph must be able to see a two (2) foot tall object at a distance of at least 500 feet to provide a safe stopping distance. A driveway permit will be denied if there is a significant problem with the stopping sight distance when an alternate access is available.

2. **Proximity to Intersections** – A corner lot will be required to access onto the minor road. Only one (1) access will be allowed (access will not be granted to each road). Exceptions may be granted for large corner lots. Driveways will not be granted within 350 feet of the right-of-way of stop sign controlled intersections, within 500 feet of the right-of-way of signalized intersections and within 1000' of the right-of-way of roundabouts. Access will be considered onto the County Trunk Highway System if the terrain (wetlands, etc.) prevents access to the minor road. Mailboxes on the County Trunk Highway will be located as far from the intersection as possible.
3. **Spacing** – Permitted driveways must meet the following conditions;
  - Minimum of 150' separation between driveways on adjacent parcels or equal to the lot frontage (applies to parcels subdivided prior to 1996)
  - Minimum 75' offset from property line
  - Minimum 350' separation between driveways on single parcels or parcels divided after 1996

Driveway requests that do not meet the conditions above will typically be denied by Department staff. Landowners may appeal the decision. Appeals will be reviewed by the Infrastructure Committee on a case-by-case basis.

**Number of Access Points** – Only one access point will be allowed per 350 feet of frontage. There is no guarantee that access will be granted to lots that have been subdivided from a larger parcel that has a single



access prior to subdividing the parcel. If additional land is located behind a row of lots which are located along the frontage, a new road may be required to give rear access to all lots that are available for development.

- 4. **Traffic** – Current traffic volume and anticipated increases in traffic and development will be considered in granting access. Every effort will be made to avoid the potential of having to buy back access as development increases.
- 5. **Maximum Surfaced Width of Access** – The following are the maximum surface width of access points.

Residential	- 20 feet	Commercial	- 35 feet
Agricultural	- 24 feet	Industrial	- 40 feet

<b>Permit Fee Schedule</b>	–	New Access	–	\$25
		Paving of existing Access	–	\$10
		Replace Existing Culvert/Driveway	–	No Fee

- 6. **Culvert Replacement as part of Pavement Replacement and Ditch Re-grading projects** – The Marathon County Highway Department will cost share culvert replacements as part of Pavement Replacement and Ditch Re-grading projects. The policy was approved at the May 2014 Infrastructure Committee Meeting.

**Maintenance**

The maintenance and replacement of a driveway, and culvert, is the responsibility of the property owner or occupant. The maintenance and replacement of intersecting side roads are the responsibility of the municipality. Any expense incurred by the

Marathon County Highway Department due to lack of proper maintenance will be at the owner’s expense (i.e., thawing of culvert pipe not cleaned, not structurally sound, obstructed by excessive snow pushed into ditch, etc.).

The typical maintenance limits where County roads intersect private driveways and Municipal side roads are illustrated in Figure 5.

**Driveway Surfacing**

Any driveway disturbed during construction activities will be restored in-kind (such as blacktop, gravel, etc), but only to the extent removed by the Highway Department personnel. Blacktop surfacing shall be permitted to the roadway surface, but typically shall conform to the normal elevation of adjacent highway shoulders, sloping down, and away from the roadway surface. At no time does the Marathon County Highway Department allow a concrete driveway surface within ten (10) feet from the edge of the roadway pavement (see **Figure 4**).

**Culverts**

All culverts must be 15” minimum diameter or larger depending on site conditions. The overall culvert size, length, and material must be approved by the Marathon County Highway Department.

**Appeal Process**

An appeal can be made to the Marathon County Infrastructure Committee on a case by case basis if the Highway Department denies a permit based on this policy. A final appeal may be made to the County Administration.

Figure 4. Highway Access / Driveway Policy

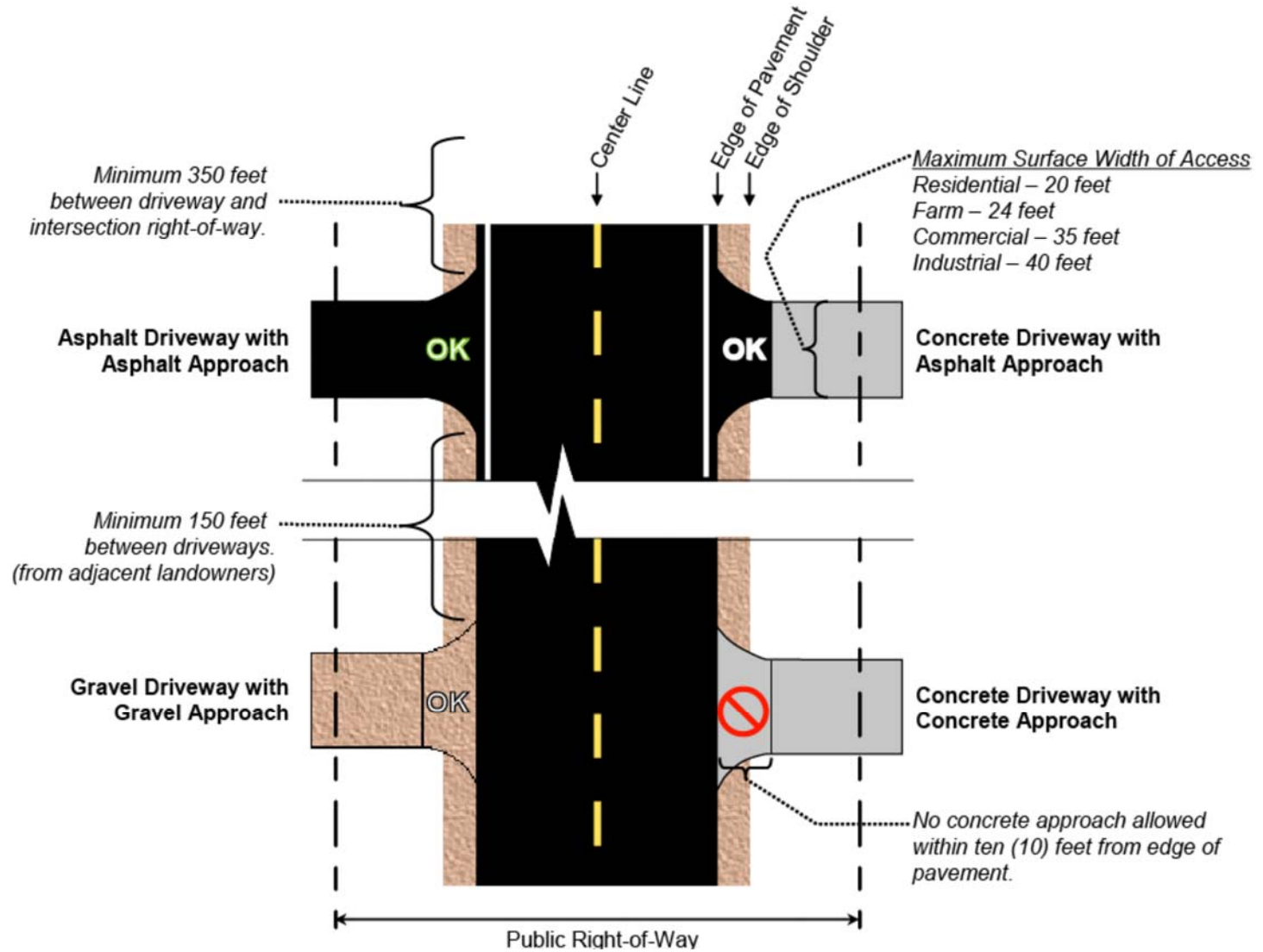





## Public Right-of-Way

---

A public right-of-way is an easement that allows the public to traverse private property. The most common right-of-ways are land owned by the county adjacent to County Trunk Highways and along recreational trails. The Marathon County Highway Department will provide right-of-way information to property owners, registered land surveyors, and utilities for county maintained roads and trails.

In addition to accommodating county highways or travel ways, the public right-of-way is commonly used to accommodate public utilities. Utility companies may on occasion work within the public right-of-way to repair existing utilities or to install new utilities to accommodate new developments

### ***Purpose***

It is the goal of the Marathon County Highway Department to provide right-of-ways which are safe and free of unnecessary hazards for the traveling public. It is also necessary for utility companies to have access to right-of-ways to provide valuable and necessary services to Marathon County residents and businesses. This section describes proper and improper uses of the public right-of-way.

### ***County Highway Right-of-Way***

Wisconsin State Statute 86.07(2) requires that the Marathon County Highway Department issue a permit for any work done within a county highway right-of-way. The county highway right-of-way is typically described by a line extending 33' or 41.25' on each side of the highway centerline (see **Figure 5**). Anyone

planning on performing work within a county highway right-of-way should contact the Marathon County Highway Department prior to starting any work. Anyone who fails to contact the Highway Department and performs work within the county highway right-of-way may be subject to a fine that is twice the current fee and will be responsible for any costs associated with correcting any work if necessary.

### ***Public Utilities***

Utilities are often located within the public right-of-way adjacent to county highways. Maintenance is common near existing utilities and new utilities may be installed to accommodate new developments. Please see the ***Utility Accommodations*** section of this manual for specific details regarding the repair or installation of utilities within the public right-of-way.

### ***Private Property***

The following sections describe common issues that arise regarding the public right-of-way and private property.



## **Right-of-Way Encroachments**

### ***Order and Notice:***

Encroachments upon the highway right-of-way in [Wisconsin §86.04](#) states in part as follows:

“If any Highway right-of-way shall be encroached upon, under or over by any fence, stand, building or other structure or object, the County Highway Commissioner (in the case of a County Trunk Highway), may order the occupant or owner of the land through or by which such highway runs, and to which the encroachment shall be appurtenant, to remove the same beyond the limits of such highway within 30 days.”

Thus, as with other encroachments to a highway, “roadside receptacle” is accidentally damaged in the process of removing snow, mowing the right-of-way graveling the shoulder, or any other act of maintenance or construction on the roadway right-of-way, it is the owner of the object, the landowner’s or occupant’s obligation and responsibility to repair or replace the receptacles.

The Highway Department may on occasion come upon right-of-way encroachments created by private property owners. An encroachment is any prohibited use or activity within the right-of-way therefore restricting the full use or purpose for which the right-of-way was established. It is the policy of the Marathon County Highway Department to review and correct these right-of-way encroachments on a case-by-case basis. Encroachments may include, but are not limited too, improperly located mailboxes, trees, signs, crops, fences, headwalls, etc.

## **Memorials**

Loss of life from a traffic crash has a devastating impact on families and friends of the victim. The Highway Department understands the distressing shock of such a loss of life and recognize that some people desire to grieve by placing a memorial within a highway right-of-way near the crash site. The Highway Department also recognizes the fact that roadside memorials may be a safety hazard. It typically is not a good idea to place memorials in the right-of-way as they distract driver attention from the road.

It is best to remove the memorial as soon as possible if it poses a safety concern, for example:

- If it is in a dangerous area (an accident already has occurred)
- If it interferes with roadway safety features or vision.
- If it negatively impacts the free flow of traffic.
- If it would be hazardous if it were hit.

A memorial may also be removed if:

- If it interferes with routine maintenance
- It falls into disrepair
- The department receives a complaint.

**Marathon County Highway Department works to mirror the guidelines noted for state highways regarding the placement and maintenance of memorials along highways located at:**

[www.dot.wisconsin.gov/business/rules/memorials.htm](http://www.dot.wisconsin.gov/business/rules/memorials.htm)







### **Miscellaneous Signs**

Any signs along roadways, including political/campaign signs, garage sale, for sale, etc. pose potential hazards. Improperly placed signs can:

- Obstruct a motorist's view
- Distract a driver's attention
- Compound damages or injuries in the event of a crash
- Endanger the safety of individuals who are erecting signs along busy highways
- Present obstacles to crews who maintain (mow) roadways

Political/campaign signs, especially larger billboard-type signs, are particularly dangerous when placed in vision areas at intersections. **Wisconsin §86.19** does provide for a \$10 to \$100 fine for signs that violate the law. **Wisconsin Administrative Rule Trans 201.16-Political Signs** and the WisDOT political sign area of their web site also provide political sign and other miscellaneous sign information.

Political/campaign sign resources:

<http://legis.wisconsin.gov/statutes/Stat0086.pdf>

<http://legis.wisconsin.gov/rsb/code/trans/trans201.pdf>

<http://dot.wisconsin.gov/business/rules/property-signs-political.htm>

Typically, the Highway Department is directed to remove political signs found within highway right of way, especially if the signs pose a safety hazard. The Highway Department will make reasonable attempts to preserve campaign signs that are taken down and to provide campaign offices with an opportunity to claim the signs.

Marathon County Highway Department works to mirror the guidelines noted for state highways regarding the placement of political signs along highways located at:

<http://www.dot.wisconsin.gov/business/rules/property-signs-political.htm>

### **Refuse Containers**

Refuse containers (including garbage and recycle containers) are not to be placed on the shoulder of roadways. They are best placed in the driveway to which they serve, off the shoulder line of the highway. Any encroachment should be brought to the attention of the local unit of government that holds the contract with the firms serving the refuse service (i.e. Town, Village, or City) for corrective action. Marathon County Highway Department does not issue written permits for the placement of containers within the public right-of-way.

### **Manure Pipelines**

Agriculture activities often require the transport of manure from lagoons or other storage areas to farm fields. Transporting this material in vehicles is costly for farm operations and results in repeated heavy loads on County Highways. To reduce agricultural operating costs and reduce heavy loads on County Highways, it is mutually beneficial for manure pipeline systems to be used for transporting material to the farm fields. Occasionally this will require the pipeline to cross a County Highway. Existing culverts are typically permitted to be used for these crossings. When an existing culvert is not available, the Department may work with farmers to install a culvert to be used. Requests for culverts should be submitted to the Highway Commissioner. Typically requests will be approved if the following conditions are met;



- The anticipated saving on the county's infrastructure is greater than the county's cost of the culvert installation.
- The applicant cost shares 50% of the project costs.
- The culvert installation won't compromise highway safety.
- The culvert installation won't compromise the highway's structural integrity.
- The culvert installation will not cause extra or unwanted water flow onto adjacent parcels.
- The project is constructed with boring equipment if the roadway pavement is less than 5 years old.
- The crossing is more than 250' from an existing culvert suitable for using as a manure pipeline crossing.

Manure Pipeline requests that do not meet the conditions above will typically be denied by Department staff. Applicants may appeal the decision. Appeals will be reviewed by the Infrastructure Committee on a case-by-case basis.

### **Mailboxes**

Mailboxes are the only structure that private owners are permitted to install within the public right-of-way. Neither the Marathon County Highway Department nor U.S. Postal Service (USPS) issue written permits for the placement of mailboxes within the public right-of-way.

### *Ownership and Liability*

The mailbox installation and support, along with the on-going maintenance and conformity with current USPS standards, are the responsibility of the property owner. All mailboxes placed within the public right-of-way are owned by the property owner

and are placed there at the owner's risk. This section of the manual is not intended to and shall not be construed to create any affirmative duty on the part of the Marathon County Highway Department to locate and remove improperly installed mailboxes.

### *Location and Installation of Mailboxes*

The proper location and installation of mailboxes can minimize potential hazards and provide for safe travel, convenient mail delivery, and effectively accommodate maintenance activities. **Figure 6** displays the proper location of a mailbox. Mailboxes should be located on the right-hand side of the road in the carrier's travel direction and should be conveniently placed so the carrier does not have to leave the vehicle to deliver the mail. All mailboxes should be mounted at a height of 42 to 48 inches from the road surface to the bottom of the mailbox. The U.S. Postal Service recommends that property owners contact the postmaster or carrier before erecting or replacing mailboxes and supports as installation recommendations may vary due to road, shoulder, and curb conditions.

### *Mailbox Supports*

Mailbox supports must be designed so that if struck, it will bend or fall away from the striking vehicle to prevent severe damage to the vehicle or injury to the traveling public. Massive supports such as telephone poles, heavy metal posts, concrete posts, antique farm equipment, or other similar items are prohibited. No other objects, including, but not limited to, landscaping boulders or fences may be placed near the mailbox. If possible, all newspaper tubes and mailboxes shall be placed on the same post to avoid unnecessary posts within the public right-of-way.



The following illustrates examples of unacceptable mailbox installations and supports:

1. Mailboxes or supports that encroach upon the travel way or shoulder of a roadway.
2. Installations with more than one vertical support.
3. A single support containing more than two mailboxes unless specifically approved by the Highway Department.
4. A support using unsafe materials stronger than a wooden 4 x 4-inch post or a 2-inch diameter metal pipe that weighs more than three (3) pounds per lineal foot.
5. A mailbox that is not U.S. Postal Service approved.
6. Adjacent mailbox installations whose respective supports are spaced closer than 30 inches measured from center of support to center of support.
7. Any neighborhood delivery or collection box units.

### *Replacement of Damaged Mailboxes*

The Marathon County Highway Department will repair or replace properly located and installed mailboxes and/or supports damaged by actual physical contact with a county highway department truck or equipment. Any mailbox that is repaired or replaced by the Marathon County Highway Department does not imply a change of ownership. The Highway Department does not provide special mailbox installations or decorative designs. The Highway Department

will provide and install a standard, #1 size conventional mailbox (approximately 7" x 9" x 18") and/or support. If a different size is preferred, the landowner must replace the mailbox at their expense.

For mailboxes damaged during snow removal activities, please see the **Frequently Asked Questions** section of this manual to determine if the county or property owner is responsible for repairing the damage.

The Highway Department will attempt to replace all damaged mailboxes within seven (7) days of being notified. However, weather conditions and/or maintenance activities (e.g., excessive snow piles, frozen ground, on-going snow removal) may delay repair or replacement of damaged mailboxes. If this occurs, a temporary mailbox may be installed until such time that the damaged mailbox can be adequately repaired or replaced.

### *Owner's Responsibilities*

**The U.S. Postal Service states that Customers must remove obstructions, including vehicles, trash cans, and snow, that impedes the efficient delivery of mail. The Highway Department also encourages the removal of snow near mailboxes to help facilitate the safe and convenient delivery of mail, reduce potential conflicts between mail delivery vehicles and the traveling public, and to reduce the possibility of damaged mailboxes resulting from repeated snowplowing and pushing of snow toward the mailbox**



Figure 7. Proper Mailbox Installation

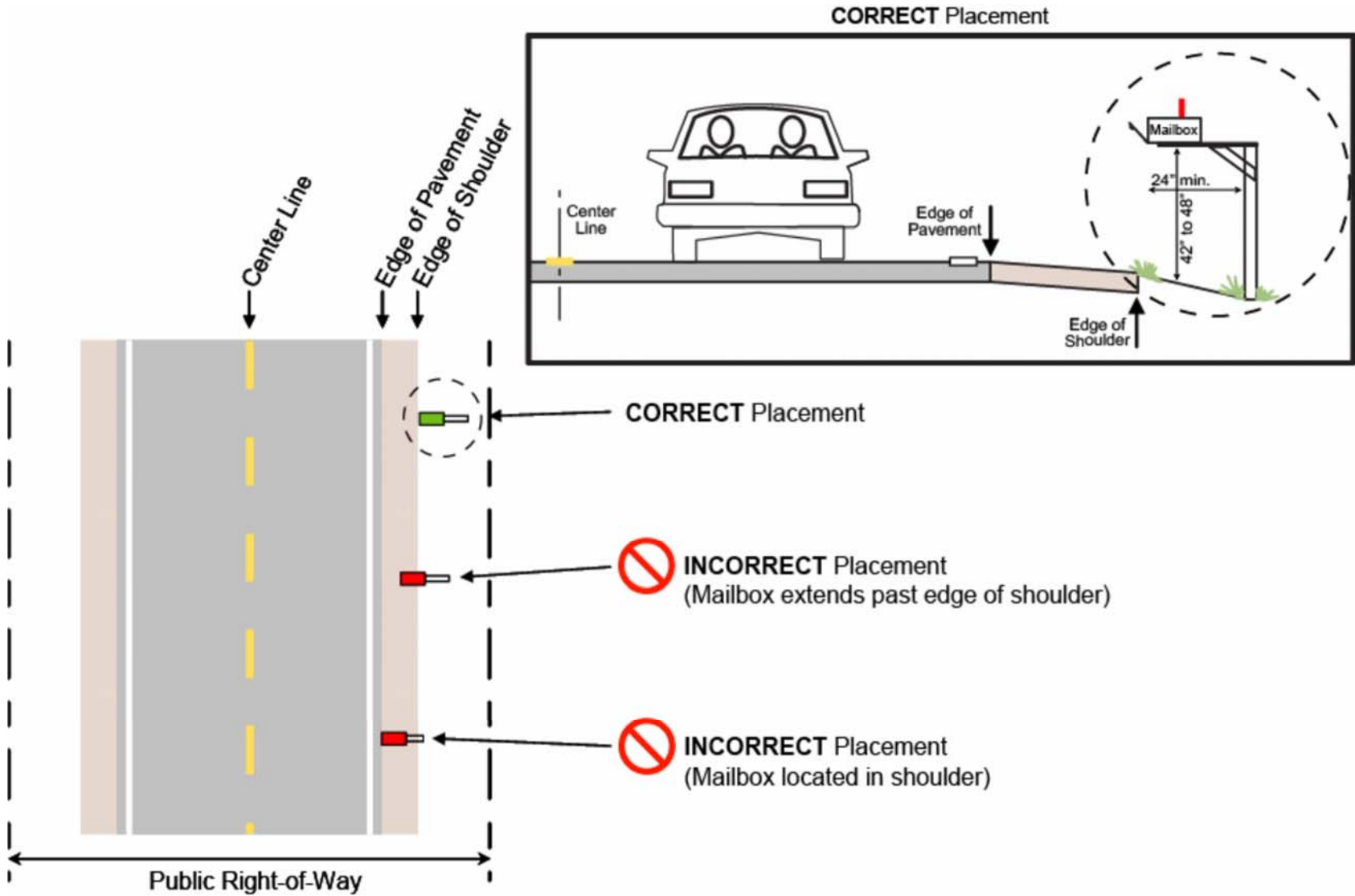



## **Plantings, Crops, and Other Vegetation**

The Marathon County Highway Department is responsible for providing a safe and reliable travelway to accommodate the traveling public. Plantings, crops, and other vegetation that is growing within the public right-of-way has the potential to create a safety hazard, may make it difficult for the Highway Department to perform routine maintenance, and may interfere with existing utilities and/or traffic control devices (i.e., stop signs, speed limit signs, no passing signs, etc.). The Highway Department will take action to correct such obstructions if they become a hazard. **Figure 7** displays an example of how planting, crops, or other vegetation might obstruct the traveling public.

### *Obstruction of Intersections*

No person shall maintain, plant or permit to remain on any private or public premises situated, at the intersection of two (2) or more roads, any hedge, tree, shrub or other growth which may obstruct the view of the operator of any motor vehicle or pedestrian approaching such intersection.

### *Obstruction of Traffic Signs*

It is unlawful for any person to plant, cause to grow, allow to grow, or maintain any trees, bushes, shrubbery or vegetation of any kind which is an obstruction to the clear and complete vision of any traffic sign. It shall be the duty of every owner of such tree, brush, shrubbery or vegetation to remove such obstruction. If the owner does not adequately maintain any trees, bushes, shrubbery or vegetation then the Highway Department will have the authority to perform the necessary maintenance including the possible removal of the obstruction.

### *Routine County Maintenance*

The Highway Department performs routine mowing and other maintenance along most County Highways throughout the growing season. In the process of mowing, or other maintenance activities, the Highway Department personnel may come upon plantings, crops, or other vegetation that encroaches on the public right-of-way. In extreme cases, the Highway Department personnel should notify the Highway Commissioner of the encroachment. The Highway Commissioner will inform the Highway Department personnel on how to proceed which may include the immediate clearing of the obstruction if it creates a potential safety hazard to the traveling public. If it is determined that the obstruction does not create an immediate hazard, the Highway Commissioner or designated department personnel may notify the property owner of the encroachment and request removal.

### *Utility Maintenance*

Utility companies may on occasion clear trees, bushes, shrubbery or vegetation that might interfere with overhead and other utilities located within the public right-of-way. This practice is done to ensure a safe and reliable provision of services throughout the County.

### *Owner Responsibilities*

A property owner may mow the portion of their property that is located within the public right-of-way. Property owners may also clear vegetation within the right-of-way. Extreme caution should be taken when performing maintenance within the public right-of-way. Please note that a permit is required when performing excavation within the county right-of-way. A permit may be obtained by calling (715) 261-1800.



Figure 8. Plantings, Crops and Other Vegetation

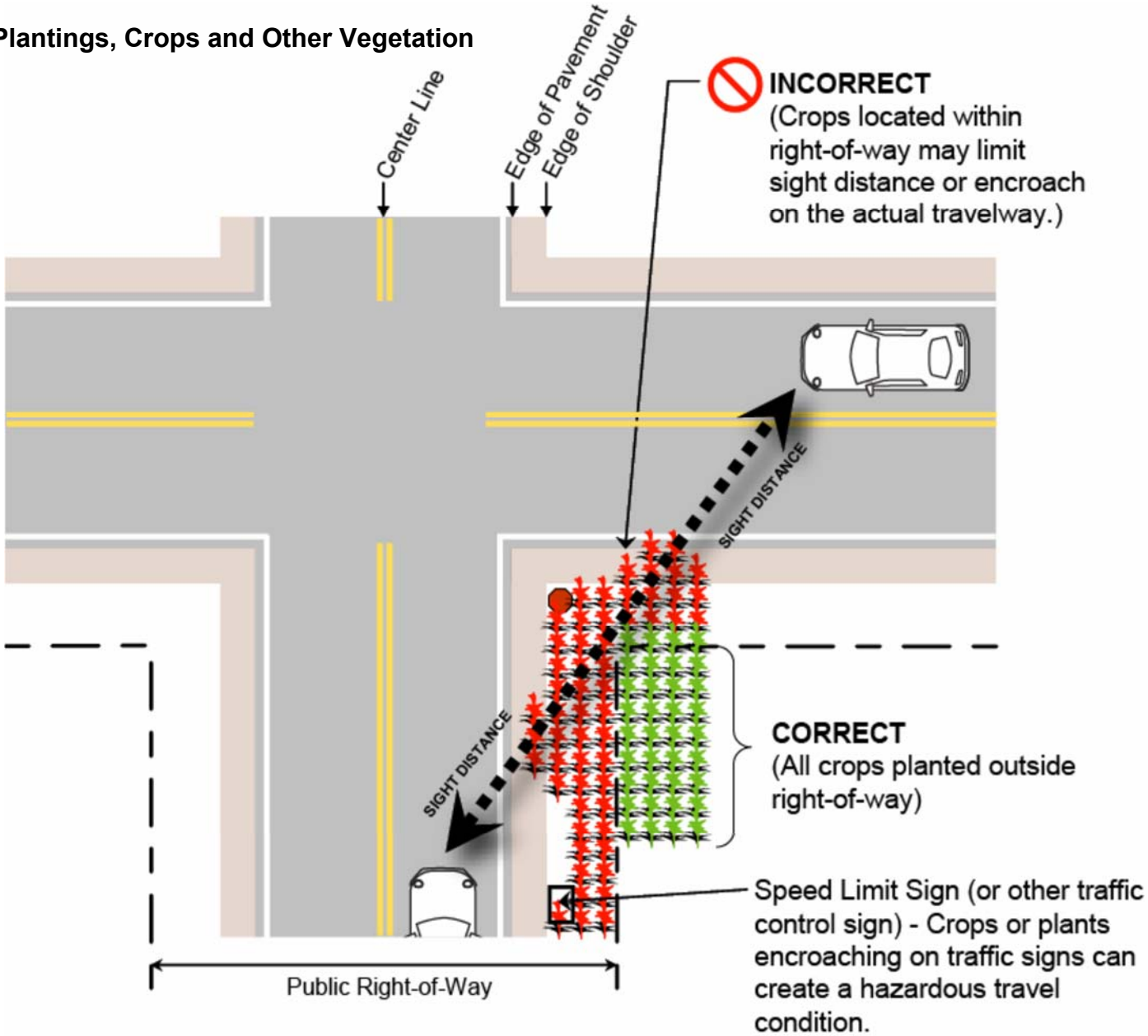



## **Trees**

Questions such as “Who owns the trees?” and “Who is responsible for their care?” often arise when trees are located near or within the public right-of-way. The following provides details regarding trees that are planted within and outside the public right-of-way. **Figure 8** displays an example of who is responsible for the care of these trees.

### *Within Public Right-of-Way*

The duty for caring for trees in the public right-of-way resides with the Marathon County Highway Department. The Highway Department will have the authority to trim, prune, or cut down trees within a public right-of-way. This is a power that the Highway Department may, not must, exercise. The Highway Department will cut down a tree if it lies within the public right-of-way and constitutes a hazard to the traveling public. Utility companies may also have the authority to trim, prune, or cut down trees that are located with the public right-of-way and may impact the utility lines or other utility services.

### *Outside Public Right-of-Way*

The duty for caring for trees outside the public right-of-way resides primarily with the property owner. If a tree overhangs or extends into the public right-of-way, the Highway Department may trim or prune the tree to improve sight distance, eliminate any obstruction of traffic control signs or devices, and other reasons as determined by the Highway Department.

In some cases it may be necessary for a tree that is located outside the public right-of-way to be cut down to improve safety for the traveling public or to eliminate potential conflicts with utility lines. Examples may include trees outside the public right-of-way that are dead, dying, diseased or severely leaning,

that could cause damage. In such cases the Highway Department will notify the property owner of the specific concern. After receiving notice that a tree is to be removed, the adjacent property owner shall have fourteen (14) days to remove the tree. Despite the landowner’s ownership of the tree, the Highway Department has the final say in who may cut it down.

### *Rights to Wood*

When it is necessary to remove trees located in the public right-of-way, the adjacent property owner shall have a right of first refusal to keep the wood. Except in cases of diseased trees (Ash Bore for example), the Highway Department may dispose of the wood to prevent the potential spread of any diseases.

## **Fences and Other Structures**

Fences and other structures are required to be located outside the public right-of-way. Wisconsin State Statute 86.03 states that no person shall build or reconstruct any fence within the public road right-of-way. **Figure 9** displays an example of the proper and improper location of fences as they relate to the public right-of-way.



### **Headwall Structures**

Headwalls, or retaining walls, while being aesthetically pleasing, may pose potential hazards to the traveling public and may hinder highway maintenance and/or snow removal. If a property owner constructs a headwall, the entire structure must be located outside the public right-of-way. **Figure 10** displays an example of the proper and improper location of headwalls as they relate to the public right-of-way. Improperly constructed headwall structures, within the public right-of-way, will be required to be removed.

### **Driveway Approaches**

All driveway approaches that connect directly to a County Highway must receive approval from the Marathon County Highway Department prior to construction. Concrete driveway approaches within the public right-of-way must be located a minimum of ten (10) feet from the edge of the pavement. Please refer to the **Driveway Permit** section of this manual and **Figure 4** for additional details.



Figure 9. Tree Care Responsibility

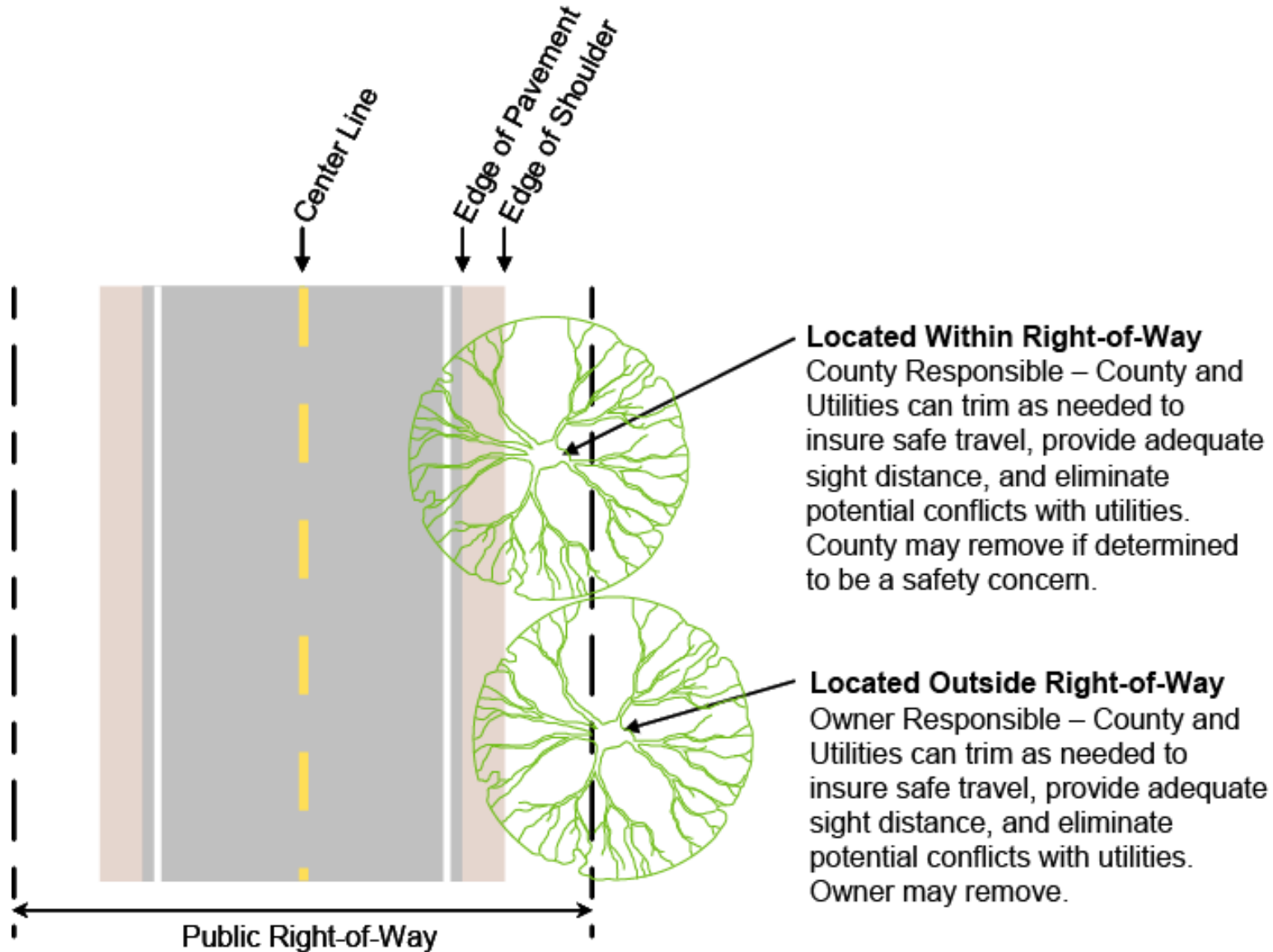



Figure 10. Proper Fence Installation

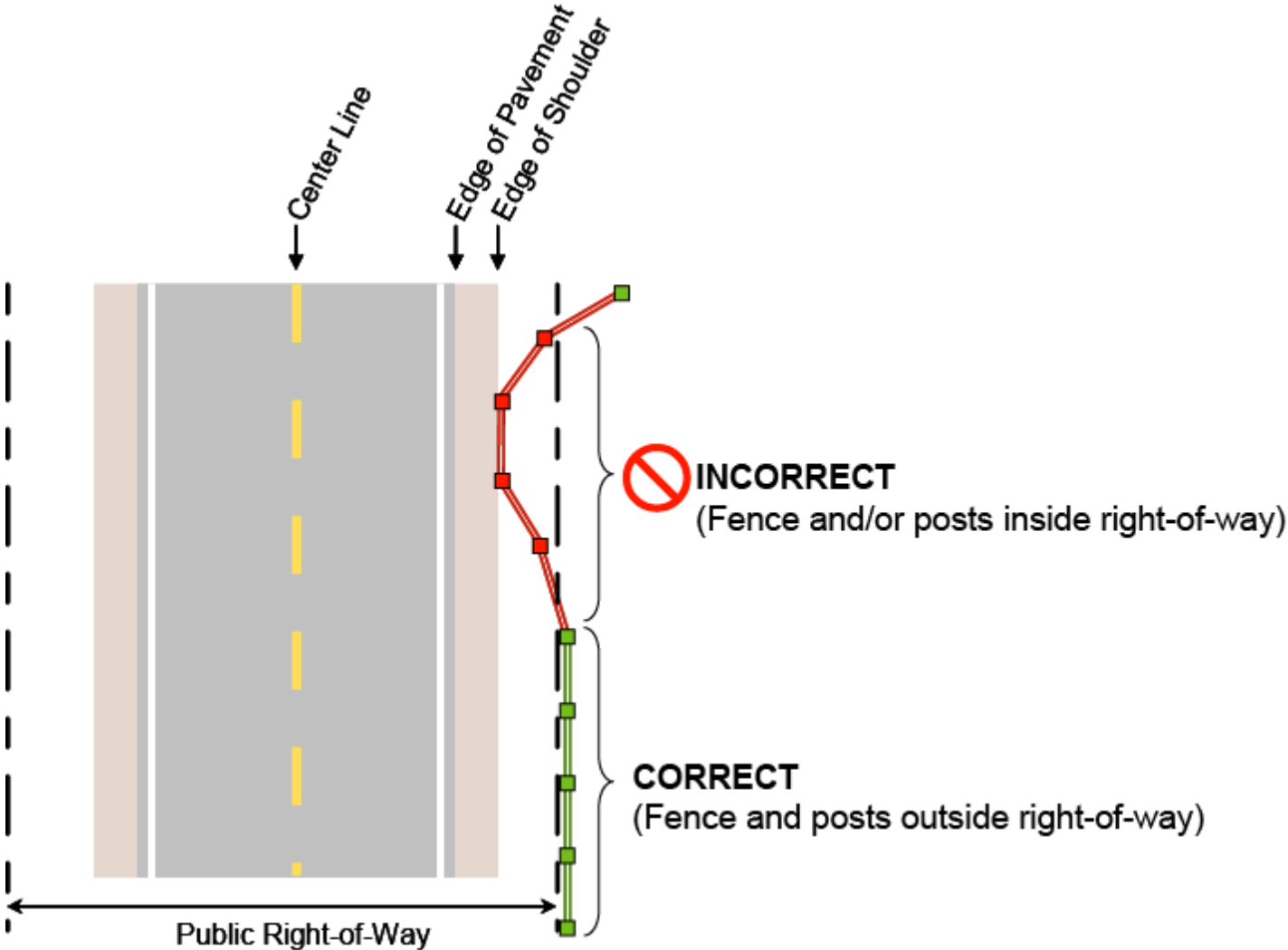
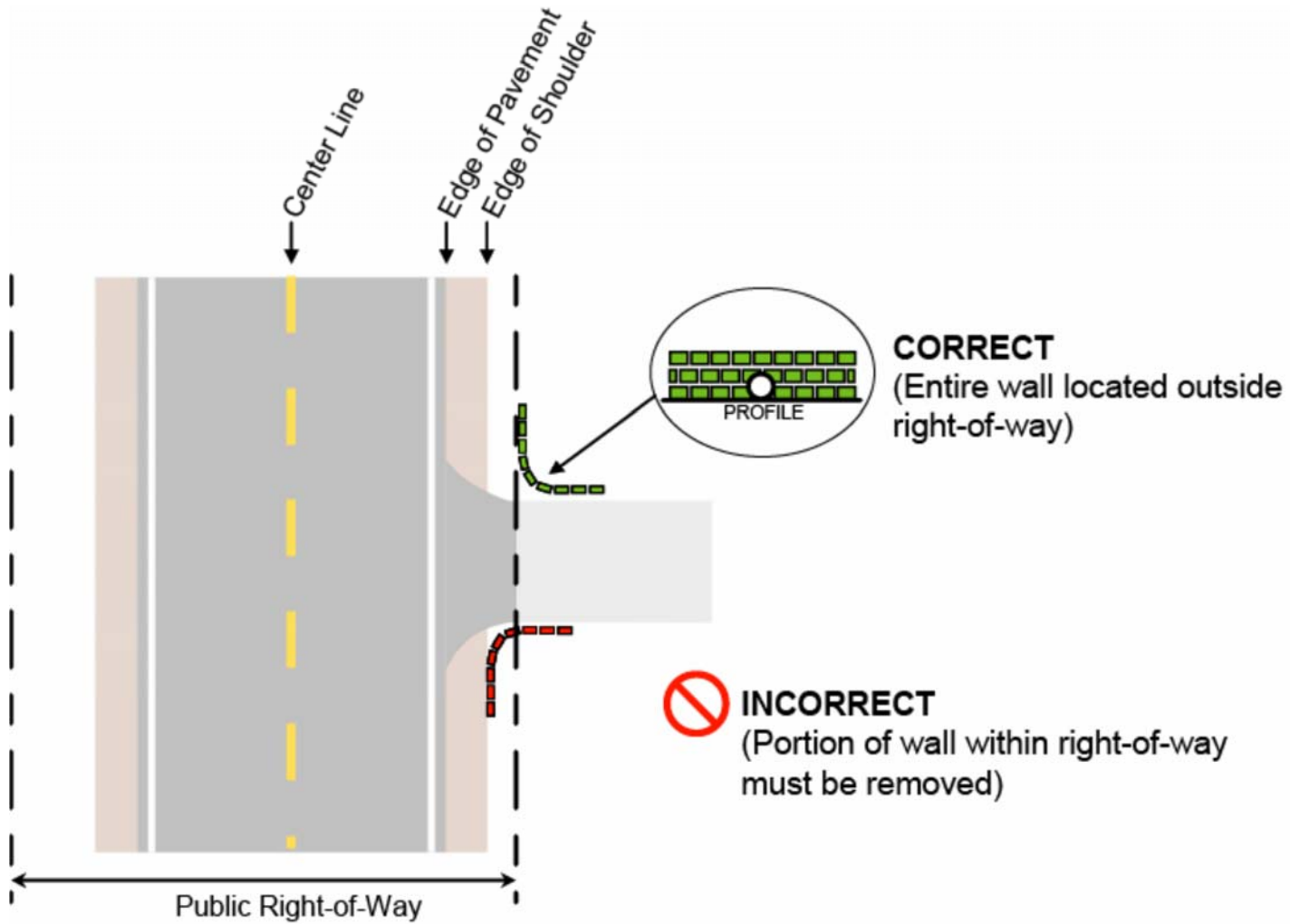

Figure 11. Proper Headwall Installation





## Vision Clearance Triangle

The vision clearance triangle (VCT) provides for proper sight distance for motorists traveling within Marathon County. The VCT is essential to traffic safety, but the VCT regulations cannot guarantee unobstructed vision due to topography, natural vegetative growth, and development that may encroach. Obstacles to be kept out of VCT need only be capable of causing a traffic hazard; they need not actually be shown to cause unsafe traffic conditions. Obstacles which may be allowed are ones which a typical motorist in a vehicle can be expected to see over, under or through reasonably enough to see approaching traffic (see section 17.26 of the General Code of Ordinances for Marathon County).

### Purpose

The VCT setbacks are intended to provide motorists a safe braking and stopping distance to avoid accidents and to provide motorists turning onto roads, streets, and highways a safe accelerating distance to merge with traffic to reduce traffic congestion.

### Standards

The following standards are taken from section 17.25 of the General Code of Ordinances for Marathon County.

1. At each uncontrolled road intersection or road-railroad intersection in any of the Agricultural Zones (A-1, A-2, A-3(M), and A-4(M)) there shall be a VCT bounded by the road centerlines and a line connecting points on them 300 feet from a Class A highway intersection, 200 feet from a Class B highway intersection, and 150 feet from a Class C highway and private easement road intersections.
2. At controlled intersections vegetation and landscape restrictions shall be as follows:
  - a. In agricultural zones, when one road has a stop or yield sign: The leg of the VCT following the centerline of the road that has no stop or yield sign shall be the length as required in Marathon County Ordinance Section. The VCT line shall extend from the end of that line to a point on the Center line of the street which has the stop or yield sign and which is 100 feet from the intersection of the centerlines of the two streets.
  - b. When both roads have stop signs, yield signs or traffic lights, or the intersection is in a non-agricultural zone, vegetation and landscape restrictions shall be as follows: The VCT line shall be bounded by the street centerlines and a line connecting points on them 100 feet from the intersection.
3. Within a VCT, no structure shall be constructed and no vegetative material shall be planted or landscaping done that causes or will cause an obstruction to view between a height of 2 ½ feet and 10 feet above the elevation of the road or highway. Vegetation or landscaping occurring in the VCT may be ordered to be pruned, trimmed, and/or removed if it is capable of causing a traffic hazard and removal of the obstacle to view has been requested by the unit of government having jurisdiction over one or more of the intersecting roads, streets, or highways, or by a law enforcement agency having jurisdiction.

Figure 12. Typical Vision Triangle

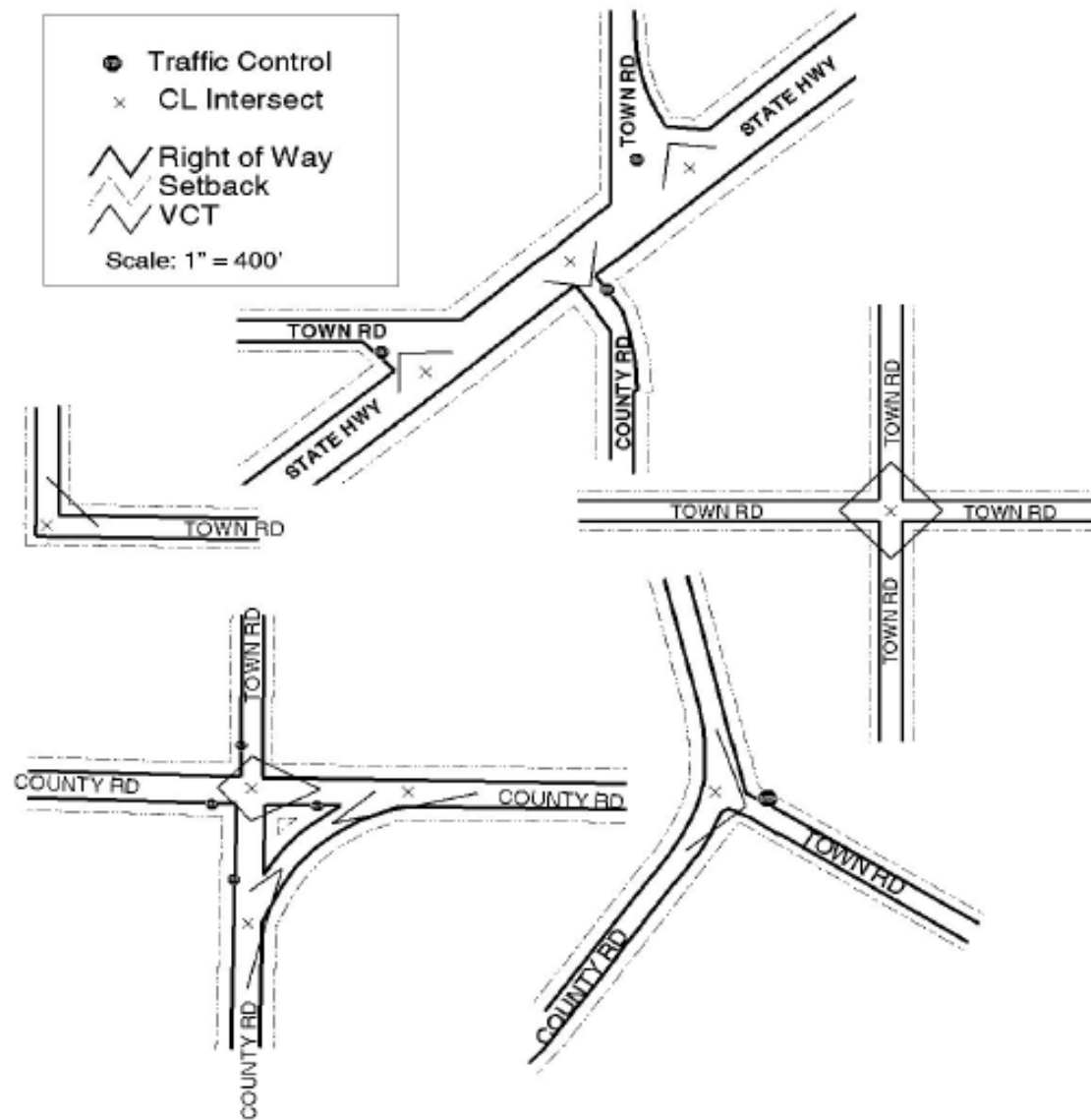





### Structures Permitted within Setback Lines

The following standards are taken from section 17.26 of the General Code of Ordinances for Marathon County.

1. Open fences.
2. Petroleum and gas transmission lines, telephone, telegraph, cable television and power transmission poles and line and portable equipment both above and below ground that is readily removable in its entirety. Additions to and replacement of all such structures may be made, provided the owner will file with the County Assistant Director an agreement in writing that the owner will move or remove all new construction, additions and replacements erected after the adoption of this chapter at his expense, when necessary to the public interest, i.e., highway construction, airport, sewer and water lines, etc.
3. Underground structures not capable of being used as foundations for future prohibited overground structures.
4. On waterfront properties, piers, wharves, erosion control structures which are part of an approved grading plan, and one pave walkway and/or stairway leading the OHWM using the most direct route practical within the view corridor. Stairs and walkways shall not exceed a width of four (4) feet. Landings not exceeding four (4) feet by six (6) feet may be authorized where the vertical rise is sixteen (16) feet or more or where a break in the slope necessitates a horizontal offset in a stairway.
5. Access or frontage roads constructed by the public to plans approved by the County Infrastructure Committee.
6. Permitted signs and signs placed by the public for the guidance or warning of traffic.

### Highway Setbacks

The following standards are taken from section 17.23 of the General Code of Ordinances for Marathon County. For the purpose of determining the distance buildings and other structures shall be setback from streets and highways, the streets and highways of the County are divided into the following classes:

#### (1) Class A Highways

- a. All State and Federal Highways are hereby designated as Class A highways.
- b. The setback from Class A highways shall be 110' from the highway centerline or 50' from the right-of-way line, whichever is greater, except that for any freeway or divided Class A highway the setback distance shall be 50' from the right-of-way line.

#### (2) Class B Highways

- a. All County Trunk Highways are hereby designated as Class B highways. For the purpose of this chapter any road will considered as a County Trunk Highway after it has been placed on the County trunk system by the County Board and approved by the State Department of Transportation.
- b. The setback for Class B highways shall be 83' from the centerline of such highway or 42' from the right-of-way line, whichever distance is greater. Buildings which were legally built at a setback of 75' to 83' from the centerline may be added to or rebuilt on the existing foundation subject to the limitations in section 17.19(1)(a)4 and 17.25 of the General Code of Ordinances for Marathon County.



### (3) Class C Highways

- a. All town roads, public streets and highways not otherwise classified are hereby designated Class C highways.
- b. The setback from Class C highways shall be 63' from the centerline of such highway or 30' from the right-of-way line, whichever is greater. Dedicated public accesses to navigable water shall not be considered Class C highways for setback purposes unless they serve a dual purpose of access to navigable water and vehicular access to adjoining parcels of land.

### (4) Private Easement Roads and Railroads

- a. The setback from private easements serving more than one residence or parcel, or from a Railroad right-of-way, shall be 30' from the described easement or right-of-way. In the case of an easement that does not have a legal description; the setback shall be 30' from the nearest point on the edge of the traveled way.

### **Reduced Building Setbacks**

The following standards are taken from section 17.24 of the General Code of Ordinances for Marathon County.

- (1) A setback less than the setback required for the appropriate class of highway may be permitted where there are existing principal buildings within 200 feet of the proposed building site that are built to less than the required setbacks. In such cases, the setback shall be no less than the average of the setbacks of

the nearest principal building on each side of the proposed site. When there is no principal building within 200 feet on one side the setback required in Section 17.23 shall be used to calculate the average. The average is not to include any building now within ten (10) feet of the right-of-way.

For the purpose of this section measurements shall be the shortest distance from the centerline or right-of-way to the building foundation or that part of the building which is totally enclosed. The intent is to discount such additions or appurtenances (not limited by enumeration) as roof overhangs, patios, decks, landings, open porches, stoops, etc. All buildings and structures shall be constructed behind the averaged setback line.

- (2) Any modification of other highway setbacks may be permitted by the Board of Adjustment according to the variance provisions. See Section 17.34(1)(b) and (c) for modification of waterline setbacks and Section 17.21(3)(d) for modification of rear yard setbacks.

### *Removal of Noncompliant Structures*

It is the policy of the Marathon County Highway Department and Infrastructure Committee to review on a case-by-case basis structures that do not meet the VCT requirements. The Highway Department and Infrastructure Committee may take action to correct the situation to meet the VCT requirements. Such action may include the removal of noncompliant structures.





## Utility Accommodations

Utility companies provide essential public services that are necessary to accommodate existing and future development throughout Marathon County. Utilities are frequently located within the public right-of-way and as such impact the maintenance and operation of County Highway system. The coordination between utility companies, contractors, and the Highway Department is essential if public services are to be provided in an effective and efficient manner. All utilities must follow guidelines illustrated in the Marathon County Utility Accommodation Policy Manual which is available at the County Highway office.

### ***Purpose***

The purpose of this section is to outline the policies and procedures that shall be met by any utility whose facility currently occupies, or will occupy in the future, any highway right-of-way or bridge over which the Marathon County Highway Department has jurisdiction.

### ***Utility Accommodations Requirements***

The Highway Department regulates the use, occupation, and utility accommodation of the county trunk highway system under sec. 66.047, 84.08, 85.15, 86.07(2), 86.16, and 182.017 of the Wisconsin Statutes. These policies apply to all existing utility facilities retained, relocated, replaced, or altered, and to new utility facilities installed within the highway right-of-way. While the Marathon County Highway Department strives to accommodate utilities whenever possible, the permitted use and occupancy of highway right-of-way for non-highway

purposes is subordinate to the primary interests and safety of the traveling public.

Traffic controls (e.g. lighting, traffic signals, etc.) and other facilities maintained and operated by the Highway Department for the purpose of ensuring motorist safety shall not be bound by the policies and procedures contained within this section.

### **Utility Permit**

An application for a utility permit must be completed and submitted to the Marathon County Highway Department. A written request detailing the utility installation and specific location must also be submitted with the application. A map outlining the county road in which the utility will be located should be provided and a schematic of the proposed work will be required along with a profile view of the bore if applicable.

### **Coordination with Planned Improvements**

The Marathon County Highway Department encourages the coordination of utility repairs and installations to be completed in conjunction with planned roadway maintenance and reconstruction. Combining the installation of utilities with road repairs is the most efficient and effective way to accommodate utilities and in the long run is better in terms of providing a sound, well maintained travel way for the public. This is of particular importance when new roadways are being constructed as it is the goal of the Highway Department to avoid unnecessary open cuts on new or nearly new roadways within the County. Any open cut utility work, regardless of how well the road is repaired, has the potential to compromise the integrity of the pavement surface, the base, and sub-base materials which can lead to significant maintenance problems and potentially shorten the life of the roadway segment.



## ***Preferred Utility Accommodations***

The Marathon County Highway Department encourages the use of boring as the preferred method to bury utility lines within the public right-of-way. The following sections outline specific actions for boring and open cut utility accommodations.

### **Boring and Trenching**

Boring is the preferred method to accommodate utilities under or parallel any County Highway. Boring is a well established trenchless method that is widely used for the installation of steel pipes and casings, especially under railways and road embankments. This method can be used advantageously to reduce damage to pavements and disruptions to traffic.

For successful execution of boring projects, the utility should survey the site conditions for surface features, subsurface geotechnical conditions and utility data should be gathered and incorporated in the early stages of design process.

While boring is the preferred method of installation, trenching is also an acceptable method for accommodating utilities parallel to any County Highway.

Any contractor or utility that plans on boring or trenching within the roadway right-of-way is required to obtain permission from the Highway Department. A \$75 permit fee is required for standard boring or trenching procedures.

### **Open Cut Policy**

If boring is not an option, and an open cut utility accommodation is necessary, the utility should notify the Highway Department of this request. The Highway Department will review the proposed utility work and will discuss potential options and

repair requirements. The decision to allow an open cut will rest with the Highway Department and will in part be based on pavement condition ratings.

### ***Pavement Condition***

Marathon County is required by State Law to collect and submit pavement condition rating data on a bi-annual basis to WisDOT (see **Pavement Management** section of this manual for additional detail). In evaluating the request for an open cut utility accommodation, the Highway Department will consider the current condition of the roadway and pavement in:

1. Determining if an open cut will be allowed,
2. Determining the appropriate permit fee, and;
3. Determining what, if any, additional repairs will be required of the utility or contractor.

The pavement condition ratings provide a general assessment of the pavement and roadway condition and are used as a basis to determine utility fees within Marathon County.

**Figure 11** displays the permit fee structure that has been adopted by the Marathon County Highway Department with regard to open cut utility accommodation. The Highway Department reserves the right to waive or modify the fees if it can be shown that the roadway has deteriorated to a lower pavement rating from current pavement rating. All expenses associated with the open cut accommodation will be the responsibility of the utility or contractor.



Figure 13. Open Cut Utility Permit Fees

Current Pavement Rating	General Description of Pavement	Open Cut Permit Fee	Additional Comments and Requirements
10 9 8	New or Nearly New Pavement.	\$1,000	The Marathon County Highway Department <b>discourages open cut utility accommodation on new or nearly new roadways</b> . Additional repairs, above and beyond standard open cut repair requirements, may be requested by the Highway Department to adequately accommodate open cut repairs that are allowed on new or nearly new roadways. These measures will be determined on a case-by-case basis by the Highway Department.
7 6	Generally Good Condition.	\$500	Additional repairs, above and beyond standard open cut repair requirements, may be requested by the Highway Department to adequately accommodate open cut repairs that are allowed on roadways in good condition. These measures will be determined on a case-by-case basis by the Highway Department.
5 4 3	In Need of Repair.	\$250	The standard utility accommodation permit fee applies.
2 1	Poor or Very Poor.	\$250	The standard utility accommodation permit fee applies. Utility company or contractor should check with the Highway Department as a roadway rated as 1 or 2 may be programmed for reconstruction. If possible, the utility work should be coordinated with planned roadway improvements.



### *Multi-Use Trails*

The construction and use of multi-use trails are becoming increasingly popular throughout Marathon County. With that comes the potential for increased requests for open cut utility accommodations along trail segments. In many cases, these trails are used year round by pedestrians, bicyclists, ATVs, snowmobiles, and other users. Maintaining these trails is important to the overall preservation of the County infrastructure. Similar to roadways, the open cut of trails is discouraged especially if a trail is newly constructed or nearly new (less than two years old). If an open cut is necessary along a county trail the following permit fees shall apply.

- Trail is under two years old - \$500.
- Trail is over two years old - \$250.

Additional repairs for trails under two years old may also be required by the Highway Department. All expenses associated with the open cut accommodation will be the responsibility of the utility. All other installation and repair requirements required for installation and repair of a utility in the right-of-way of a road shall apply to the right-of-way of multi-use trail (see **Installation and Repair Requirements** section of this manual for additional detail).

### ***Installation and Repair Requirements***

All utility work within the public right-of-way is subject to review and approval by the Highway Department personnel. The preferred utility accommodation, boring, is the least intrusive technique, in particular to the roadway surface. In the long term, boring will have the least impact on the integrity of the roadway surface.

### **Prior to Beginning Work**

Before commencing any work on Marathon County roads or within the County right-of-way, the utility or contractor shall notify the Highway Department of the approximate time that work will commence. This notice shall be at least forty-eight (48) hours prior to commencing any work.

### **On-Site Requirements**

Traffic control devices (i.e. signs, cones, etc.) must be used when work is being performed in the public right-of-way. The utility or contractor should make every effort to minimize the disruption of traffic when working within the public right-of-way.

### **General Requirements**

1. Any utility lines should be installed as near as practical to the outside limits of the public right-of-way. This is also to include above ground installation and the setting of utility poles.
2. Contractors should use care when loading and unloading equipment within the public right-of-way. No ditching machinery shall be operated upon the crown of any roadway unless specifically permitted by the Highway Department. The Contractor shall pay for any damage to the roadway or right-of-way.
3. The applicant will remove and relocate its utility lines should it become necessary in order to accommodate widening, realigning, and/or improving County roads at no cost to Marathon County.
4. The applicant shall, from the commencement of the installation of utility lines and thereafter for a period of twelve (12) months from the date the installation is



completed and accepted, assume all responsibility for damages resulting to the landowner or to any other person caused by the installation of the utility lines and shall hold Marathon County harmless from any obligation or claim or damages that may be alleged or result from such utility construction or operation.

5. The applicant will be responsible to reimburse the Highway Department if the Department must repair any work performed by the utility or contractor during a twelve (12) month period following completion of the utility installation.

### **Open Cut Repair Requirements**

The Highway Department has the authority to require more extensive repairs of open cut utility accommodations, especially if the open cut is allowed on new or nearly new roadways. These repairs may be required in order to preserve the long-term integrity of the roadway surface, base, and sub-base. Specific repairs will be identified and approved by the Marathon County Highway Department on a case-by-case basis. As a minimum standard, at all points where excavations are made in the public right-of-way, the applicant will replace and recompact the base and sub-base and will restore the roadway section to the same or better condition as existed prior to the excavation.

### ***Authority to Enforce Policy***

The Highway Commissioner, or designee of the Marathon County Highway Department, has the authority to enforce the Utility Accommodation Policy and the specific requirements of an individual utility permit. All utilities, including all consultants, contractors, and subcontractors working for utilities, are

required to abide by the policy and the specific provisions related to individual utility permits.

### **Failure to Comply**

Failure to comply with the Utility Accommodation Policy will result in corrective actions and/or monetary penalties against the Utility. At the Highway Department's option, the following measures may be taken if a Utility fails to comply with the policy or specific permit provisions.

**1. Verbal Request for Corrective Action** – The request shall include:

- a) The reason(s) why the present or completed operation is (was) not in compliance with the Policy or the permit provisions,
- b) What steps shall be taken to correct the situation, and
- c) What additional action may be taken if step b is disregarded (items that follow).

**2. Written Reprimand** – A written reprimand shall be sent to the utility for violating the Policy or its permit provisions when the utility does not comply with the verbal request. The written reprimand shall contain the same information as the verbal request and shall serve as documentation for the violation. The Marathon County Highway Department shall be responsible for writing and sending this reprimand.



**3. Suspension of Work Activities** – If a responsible person of an inspected work site fails to comply with a verbal request, the inspector may order the suspension of all work activities at the site. If this occurs, the Marathon County Highway Commissioner shall be informed of the situation. The Highway Department shall then contact an authority of the utility to explain why the operation was suspended and what action needs to be taken before work can resume.

**4. Removal of Installed Facilities** – Any facility installed by a utility shall be in the location shown on the approved permit. If such a facility is discovered in an unacceptable location, and the utility is notified, the utility shall have two weeks' response time to decide on its corrective action. If the utility fails to take corrective action, the Department shall take action to have that facility relocated or removed at the utility's expense. The permittee shall remove the improperly placed facility and put it in an approved location. If the utility fails to relocate its facility the Department shall have the facility removed and bill the permittee for such work.

**5. Permit Revocation** – If a utility continues to be in noncompliance with the policy or specific permit provisions, the Highway Department may revoke the utility's permit. The utility may reapply for a permit to the Highway Department when it can demonstrate a good faith effort to comply.

**6. Public Service Commission (PSC) Notification** – Continued violations by a utility of the Policy or its permit provisions may cause the Department to notify the PSC and request its assistance in correcting the situation.

**7. Withholding Approval of Future Permits** – Continued violations by a utility of the Policy or its permit provisions may cause the Department to withhold approval of permit applications for that utility until the violations are corrected to the satisfaction of the Department. The severity and number of written reprimands against a utility may serve as a guide in determining future permit approval.

**8. Fee Penalties** – Any utility that violates the County's utility accommodation policy will be subject to follow:

- a) Cost of the permit.
- b) Penalty – Twice the current permit rate.
- c) Costs of Corrective Actions – The utility will be responsible for all costs associated with repairs or additional work.
- d) After the Fact Permit – Twice the current permit rate.

**9. Appeal Process** – The utility must first appeal to the permit reviewer, Highway Commissioner, and Committee with assistance of their Corporation Counsel.



## Road Debris and Obstructions

The Marathon County Highway Department is responsible for keeping the county highways free from dangerous obstructions including storm debris, dead animals, farm debris, and other various roadway obstructions.

### ***Purpose***

It is the goal of the Marathon County Highway Department to provide public travel ways that are safe and free of unnecessary hazards. Highway and/or roadside debris may at times compromise public safety. This section outlines a process for keeping roadways free of debris and obstructions.

### ***Debris and Obstructions***

The public is encouraged to report any unsafe conditions observed on the County Highways. Downed trees, road obstructions, debris should be reported as soon as possible. Road hazards on County Maintained Highways may be reported to the Marathon County Highway Department during normal business hours. Hazards may be reported after hours by calling 911 and notifying the Marathon County Sheriff's Department.

### **Litter**

Wisconsin law prohibits intentional littering. The majority of litter will likely not impact safety but does impact aesthetics along the county highway system. Marathon County has an adopt-a-highway program which promotes anti-litter campaigns within the County. Details regarding this program are provided in the **Adopt-A-Highway** section of this manual.

### **Storm Debris and Obstructions**

Storm debris can create unsafe travel conditions along county highways. Fallen trees and/or temporary flooding of low lying areas are common storm related problems. The public should use caution when handling storm debris as there could potentially be hazardous items including downed power and utility lines in the area.

#### *Removal of Fallen Trees*

If any tree falls from adjacent land into any highway, the owner or occupant of the land shall immediately contact the Highway Department. The Highway Department may assist in the removal in certain situations.

### **Animal Removal**

The Marathon County Highway Department when needed provides large animal removal from County roadways (dead deer removal service is provided by the Wisconsin Department of Natural Resources). If the animal remains create a road hazard please call 911 and report the location to the Marathon County Sheriff's Department.

### **Farm Debris**

Any debris that is left on a County Highway as a result of farming activities should be promptly removed by the farmer, contractor, or property owner. If the debris creates an immediate hazard the Highway Department may remove the hazard at the property owner's expense.



## **Snow and Ice**

The pushing of snow and other materials onto or across the highway, or into the public right-of-way, from side roads and driveways is prohibited by Wisconsin Statutes 86.01, 86.07, and/or 346.94. Doing so may create potential safety concerns for the traveling public and may impede the snow and ice removal process. Furthermore, snow shall not be stored in any manner which will obstruct or limit vehicular or pedestrian vision, movement, or access. If the Highway Department becomes aware of a violation, the property owner may be subject to a fine.

### *Public Notification*

At least once each year the County shall remind the public of this safety concern through the news media. A typical notice is included to the right.

### Example of Public Notification

PUSHING SNOW OR OTHER MATERIALS ONTO OR ACROSS HIGHWAYS FROM PRIVATE DRIVEWAYS CAN CAUSE ACCIDENT AND DEATH, AND IS PROHIBITED BY WISCONSIN STATUTES 86.01, AND/OR 346.94(5). Doing so may create potential safety concerns for the traveling public and may impede the snow and ice removal process. Furthermore, snow shall not be stored in any manner which will obstruct or limit vehicular or pedestrian vision, movement, or access.

Obstruction of vision clearance triangles at intersections is prohibited by 86.191 of State Statutes and by Sections 2.16 of the County Zoning Ordinance. Placing mailboxes away from driveways and intersections helps to avoid vision restricting snowbanks in late winter, and helps to avoid damage to your mailbox. The nearest part of your mailbox should not be closer to traffic than the shoulder line, with box and base strong enough to withstand wind, flying snow and slush from traffic and snowplows.

Avoid penalty and liability, and cooperate towards safer highways. The life you save may be your own. Marathon County Highway Department, Marathon County Towns & Villages cooperate with the County Sheriff's Office, and the County Highway Safety Commission to enforce these laws.

BY ORDER OF THE MARATHON COUNTY  
INFRASTRUCTURE COMMITTEE & MARATHON COUNTY  
TOWNS & VILLAGES.





## Adopt-A-Highway Program

The Marathon County Highway Department has developed an Adopt-A-Highway program which allows organization (or groups) to volunteer and support the County and State anti-litter efforts.

### Purpose

The program offers groups an inexpensive project that gives its members the satisfaction of making a contribution to their community and their state. At the same time, the Adopt-A-Highway program generates publicity for the group’s service activities.

### Application Process

Interested organizations may obtain Adopt-A-Highway application materials from the Marathon County Highway Department during regular business hours (Monday – Friday, 8:00 a.m. to 4:00 p.m.). Any organized group may volunteer to participate; however, partisan political groups are not permitted. Application materials can be requested in person or by calling (715) 261-1800.

The Highway Department will provide application materials which will include:

- a) A detailed description of the Adopt-A-Highway program and requirements.
- b) A county map the group can use to request a highway segment for the Adopt-A-Highway program.

- c) An application form that must be completed and returned to the Highway Department for approval.

### Approval Process

The Marathon County Highway Department will review the completed application materials and each qualified group will be assigned a nominal two-mile segment of county highway for litter control. The Highway Department will provide a permit to work within the highway right-of-way and further instructions. Prior to beginning any work on the roadways, the group should watch the safety video located at <http://www.dot.wisconsin.gov/localgov/aid/adopt-a-highway.htm>

### Signage

A sign, with your group’s name, will be placed at the beginning and end of the highway segment. The sign announces to the motoring public your group’s sponsorship for litter control. Each group may request the name (or acronyms) that will appear on the signs. Up to two (2) lines and 40 characters (20 characters per line) will be allowed (see example below).

#### LINE 1

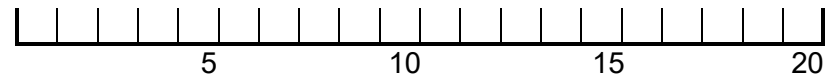

#### LINE 2

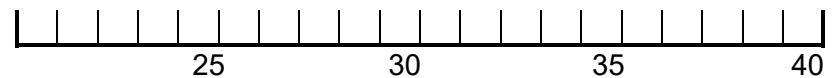

The Marathon County Highway Department reserves the editorial right to work with sponsors to revise group names and/or acronyms that might be offensive to the general public.



## **Adopt-A-Highway Program Requirements**

The Adopt-A-Highway program is intended to provide an opportunity for groups to participate and contribute to the overall beautification of the County. There are however requirements that must be followed to maintain good standing. These requirements include the following:

### **Annual Requirements**

- 1) The group must pick-up litter on its designated highway segment at least two (2) times a year between April 1 and November 1.
- 2) The organization may retain their designated highway section if they are in compliance with all the Adopt-A-Highway Requirements. It is the organizations responsibility to send a letter to the Marathon County Highway Department on an annual basis notifying the Highway Department that the organization desires to continue in the program.

### **Age and Supervision Requirements**

- 1) All workers must be at least 11 years of age or in the 6<sup>th</sup> grade to participate in the roadside clean-up.
- 2) The group will be required to provide one (1) adult supervisor for every four (4) workers. This adult supervisor will be designated as the crew chief.
- 3) The crew chief should keep the workers together as a team and is responsible to enforce all safety rules.

- 4) The crew chief should carry a first aid kit at all times and should be aware of the nearest emergency room and the best route to reach it before beginning any cleanup work.
- 5) The crew chief should carry a cell phone.
- 6) Only eligible, group volunteers should be in the designated roadside cleanup area. No other persons should be on the work site.

### **Safety Requirements**

- 1) The group will at all times emphasize safety when traveling to/from the designated Adopt-A-Highway segment and when working in the roadside cleanup area.
  - a. All workers are required to review the safety video located at the Wisconsin Department of Transportation website (see link below). Review of the safety video should be completed by the group on an annual basis (at a minimum) and should be shown to any new volunteers before participating in a cleanup session.  
<http://www.dot.wisconsin.gov/localgov/aid/adopt-a-highway.htm>
  - b. The group (crew chief) will hold a safety meeting at the beginning of each clean-up day. This meeting is intended to ensure that each person is fully aware of the safety precautions and that everyone is as protected as possible. This meeting should take place prior to arriving at the designated highway cleanup area.
  - c. All workers are required to wear safety vests at all times. Hiking boots, or shoes with thick soles, are



recommended to prevent foot injuries from any sharp objects. Additional items that are recommended include work gloves, sun screen, baseball caps or wide-brimmed hats, long sleeve shirts, and long pants.

- d. The group will not work in potentially dangerous areas including the pavement (traveled way), shoulders, medians, bridges, tunnels, overpasses, and steep slopes.
- e. The group should only conduct a cleanup session between 7:00 a.m. and 7:00 p.m. and when adequate daylight is available. The group should not work during inclement weather.
- f. Group volunteers should avoid overexertion and everyone should know their physical condition and limitations. The crew chief should be aware of any special needs of any crew members.
- g. Group volunteers should stay alert for any potential hazards including snakes, stinging insects, ticks, poison ivy, mowing equipment, construction equipment, parked cars, and other equipment.
- h. Group volunteers should stay mentally alert while at the designated roadside cleanup area. No one should use headsets, stereos, and radios as this could distract volunteers and make it difficult to hear oncoming traffic.

- i. The group should bring plenty of water, especially on hot, humid days, and alcoholic beverages are not permitted at the designated roadside cleanup area.

### **Transportation to the Cleanup Area**

- 1) The group should meet at a safe location prior to proceeding to the designated roadside cleanup area. This meeting location provides a good opportunity to conduct the safety meeting before traveling to and beginning the roadside cleanup.
- 2) The group should carpool to the designated roadside cleanup area and use as few vehicles as possible.
- 3) All vehicles should park parallel to the road and at least three (3) feet away from the pavement surface before unloading the group. All vehicles should park on the same side of the road that the group plans to work on. (see **Figure 12** for an example).
- 4) Upon arriving at the cleanup area (see **Figure 13**), the group should place highway worker signs at the beginning and end of the cleanup area. The signs should be positioned to alert on-coming traffic, from both directions, that workers are present.
- 5) The group should be driven to the opposite side of the highway when it is ready to switch sides. The crew chief should not allow any member of the crew to walk across the pavement to the opposite side of the highway.
- 6) When the cleanup is complete, the group should close the highway worker signs.



### **Handling the Litter**

- 1) Group volunteers should not touch or pick-up anything that cannot be identified. Some materials may be hazardous (hazardous materials are commonly found in closed metal containers). These items should be flagged using the flags provided by the Highway Department.
- 2) The group should flag any item that they do not want to pick-up.
- 3) Do not overload the trash bags as this could cause the bag to break and make the pick-up more difficult.
- 4) The group may keep any recyclable materials that are collected. A trash bag may be used to remove these materials from the site.
- 5) Place filled trash bags at the designated pickup site. The Highway Department will collect the filled trash bags and flagged items from the designated roadside cleanup area.

Figure 14. Parking at the Roadside Cleanup Area

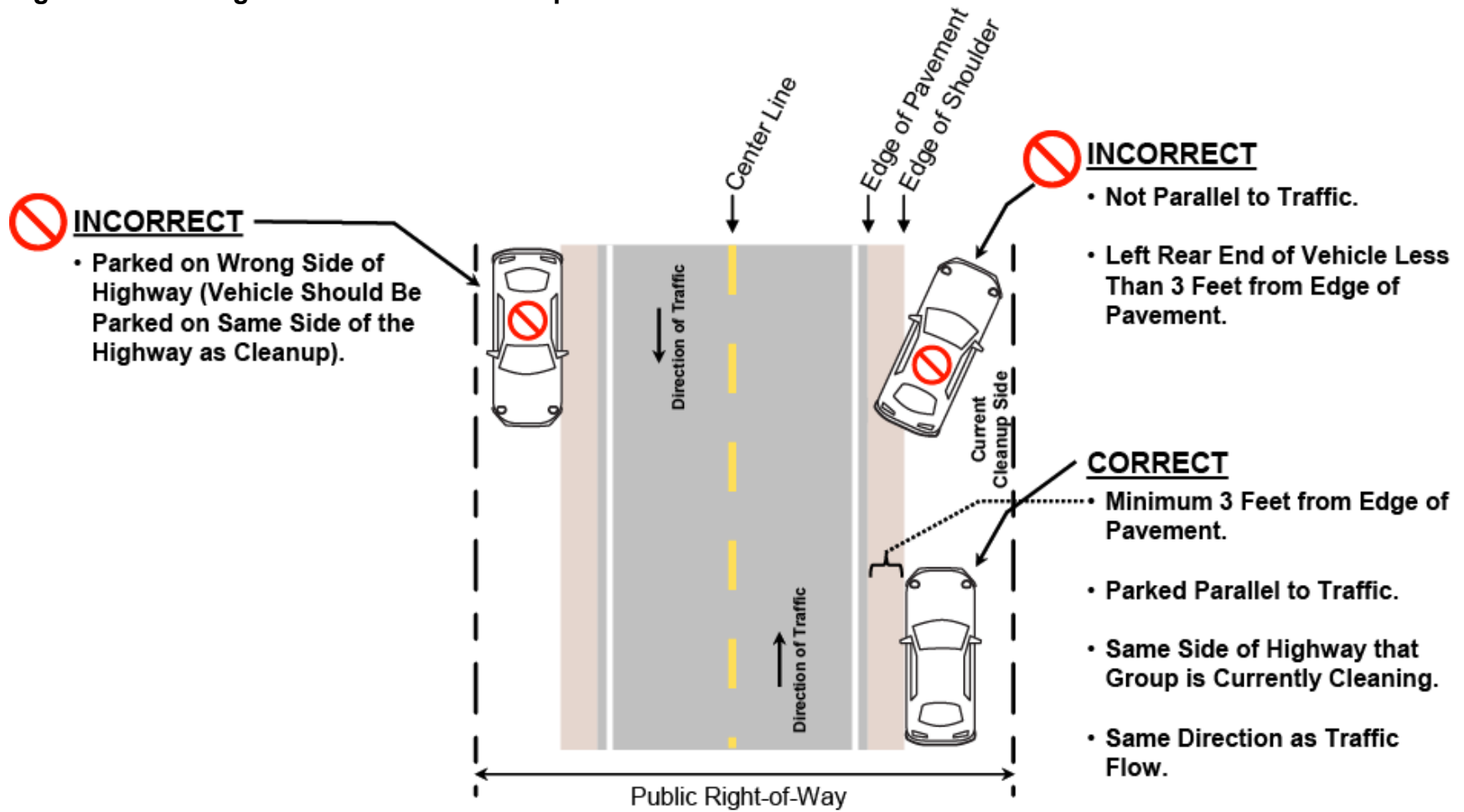
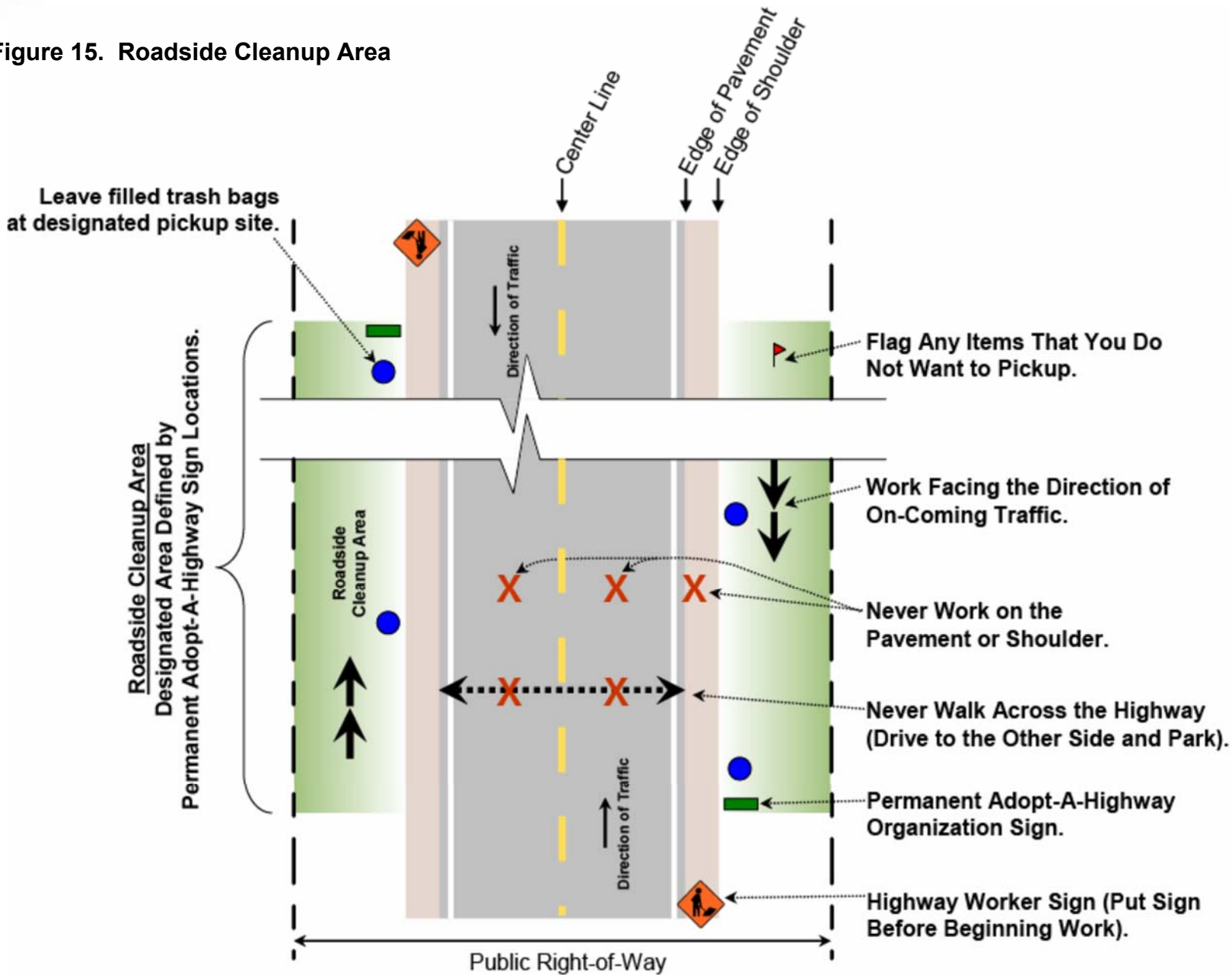



Figure 15. Roadside Cleanup Area





## **Snow and Ice Removal**

The Marathon County Highway Department is responsible for the snow and ice removal (referred to as snow removal) of approximately 612 miles of County Trunk Highways and an additional 700 lane miles of State Highways through contract with the WisDOT. Snow removal activities may occur any time of the day or night and likely requires overtime by the Highway Department personnel. Careful planning and preparation must be done prior to the winter season to ensure the safe and efficient snow removal throughout Marathon County.

### ***Purpose***

The purpose of this section is to define the level of expectations for snow and ice removal of County maintained roads during a winter storm event. The primary goal of winter maintenance is to achieve “passable roadways” within the limitations imposed by climatological conditions, the availability of resources, and environmental concerns during a winter storm event.

### ***Snow Removal Procedures***

The following section outlines the snow removal procedures used by the Marathon County Highway Department. Exceptions to this policy may occasionally be necessary as dictated by weather and road conditions.

### **Decision to Begin Snow Removal**

Several factors impact when the Highway Department begins the snow removal process. These factors include, but are not limited to, current roadway conditions, current weather conditions, forecasted weather conditions, and the time of day.

Each storm presents unique challenges which must be dealt with accordingly. Given the overall size of Marathon County, it is possible for weather and road conditions to vary greatly from one area of the County to another area. The Highway Department will take all factors into consideration and will make a determination on the appropriate time to begin the snow removal process.

### **Snow Removal Methods**

The primary method of snow removal shall be by plowing. Salt, sand/salt or salt with other additives may be used to enhance snow removal or to improve traction. Motorists should expect that snow will be plowed into cross streets and driveways as a normal part of snow removal operations.

### **Passable Roadway**

The intent of the snow removal process within Marathon County is to maintain a safe environment for the traveling public. This does not mean that the traveled portion of a roadway will be cleared to the pavement. In fact, the public should be aware that the traveled portion of a roadway and/or bridges will, at times, have snow and/or ice which will create slippery conditions. Motorists should be aware of these conditions and should exercise caution when driving during these conditions.

The goal of the Highway Department is to create a “passable roadway.” A passable roadway is defined as a roadway surface that is free from drifts, snow ridges, and as much ice and snow pack as is practical and can be traveled safely at reasonable speeds. A passable roadway should not be confused with a “dry pavement” or “bare pavement”, which is essentially free of all ice, snow, and any free moisture from shoulder to shoulder. This “dry/bare pavement” condition may not exist until the weather



conditions improve to the point where this pavement condition can be provided.

The definition of "reasonable speed" is considered a speed that a vehicle can travel without losing traction. During and immediately after a winter storm event, a reasonable speed will most likely be lower than the posted speed limit. Motorists can expect some inconvenience and will be expected to modify their driving practices to suit road conditions.

### **Level of Service and Hour of Operation**

The level of snow removal service depends on the type of roadway being serviced. The Highway Department maintains both State and County roadways. These roadways are divided into three (3) classes which determine the priority, level of service, and hours of operation. The three classes of roads shall be serviced as described in the following.

#### *Class One (1) Roads*

Class one (1) roads are defined as Interstate highways and other major state routes. These roadways are subject to specific service WisDOT requirements. These roadways may be serviced twenty-four hours, seven days per week. For additional information you may view the WisDOT website at:

<http://www.dot.wisconsin.gov/travel/road/winterbrochure.htm>

#### *Class Two (2) Roads*

Class Two (2) roads are defined as those routes having an average daily traffic (ADT) volume of 1,000 vehicles or more. Snow plowing services on class two roads will include regular service (4:00 a.m. to 9:00 p.m.), reduced service (9:00 p.m. to 4:00 a.m.), and emergency service.

#### *Class Three (3) Roads*

Class Three (3) roads are defined as those routes having an ADT volume of less than 1,000 vehicles. Snow plowing services on class three roads typically include regular service (4:00 a.m. to 9:00 p.m.) and emergency service primarily during the hours of 9:00 p.m. to 4:00 a.m.

The majority of snow removal within Marathon County will occur between the hours of 4:00 a.m. and 9:00 p.m. It should be noted that these service hours are provided as a guideline and may be modified on a case-by-case basis. With the exception of twenty-four roadways, the Highway Department will provide reduced service on County Roads beginning at 9:00 p.m. The Highway Department will also provide emergency service between 9:00 p.m. and 4:00 a.m. primarily at the request of the Marathon County Sheriff's Department. The Highway Department maintains communication with the Sheriff's Department and will respond to specific requests of the Sheriff's Department.

### **Standing Corn Row Snow Fence Program**

In certain locations, corn left standing parallel to a roadway can work well as a snow fence. Landowners can enter into a program where the County will pay the market price plus \$0.50 more per bushel to leave corn stalks standing. Payment is based on the July market price published by the National Agriculture Statistics Service (NASS). For current prices, go to [www.agriculture.com/markets/commodity-prices](http://www.agriculture.com/markets/commodity-prices).





### **Road Conditions**

Winter road conditions can be found at:

<http://www.dot.wisconsin.gov/travel/road/winter-roads.htm>

### **Service Areas**

**Figure 14** displays the current snowplow routes for State Highways while **Figure 15** displays the current snowplow routes for County Highways. The Highway Department reviews snow routes on a regular basis and make adjustments as needed to most effectively and efficiently accomplish the snow removal process.

### **Snow Emergency**

A snow emergency may be declared when the visibility declines to a point that it is hazardous to the driving public or snowplow operators to be on the roads. Under these conditions, snowplowing and/or ice control operations may be suspended until visibility improves. The Highway Department, may on occasion determine that it is in the best interest of the traveling public to close a road, or roadway segment. When a snow emergency is declared, the Highway Department will notify the Sheriff's Department, WisDOT, and if possible, local media regarding the specific concerns of the emergency. When a snow emergency has been declared, the level of service, snow removal hours, and/or department personnel hours may be adjusted as needed to best accomplish the snow removal process.

### *Authority to Declare*

The Highway Commissioner will have the authority to declare a snow emergency. In the absence of the Highway Commissioner, an appointed Highway Department designee will have the authority to declare a snow emergency.



Figure 16. Snowplow Route (State Roads)

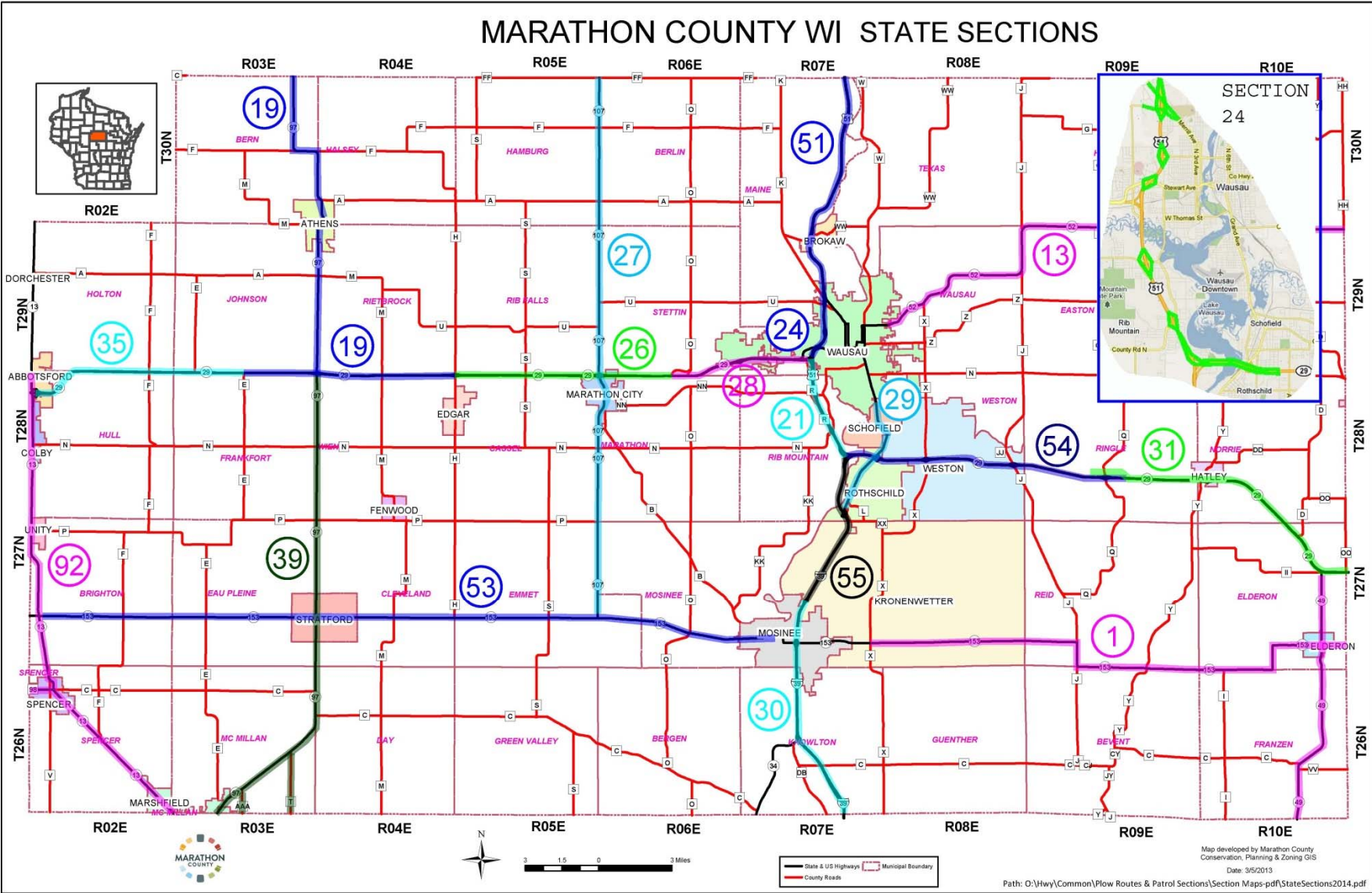
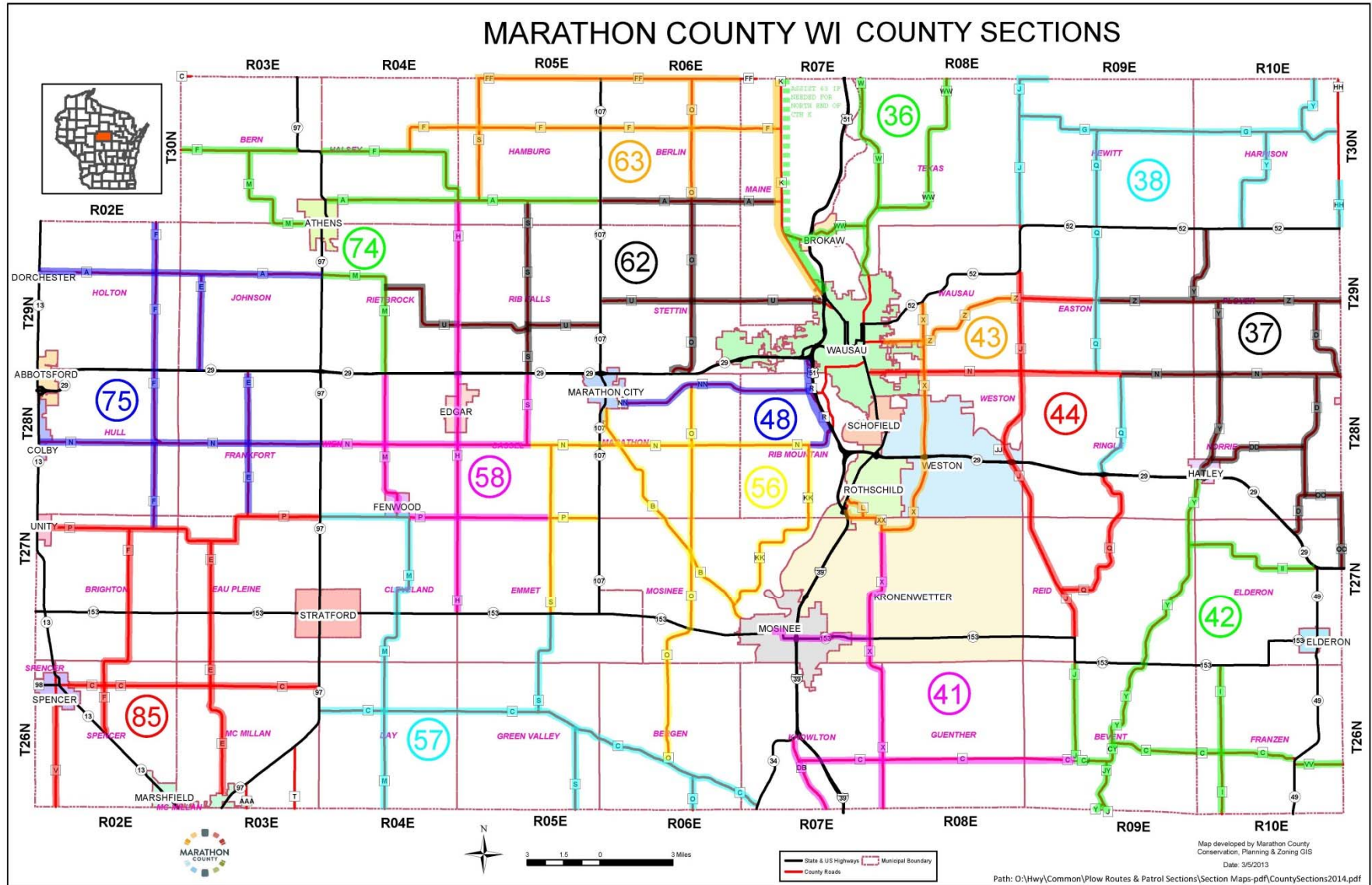



Figure 17. Snowplow Routes (County Roads)





### **Highway Department Personnel**

Snow removal is a long and tiring process that may require drivers to work overnight. It is a primary concern of the Highway Department to maximize safety for the traveling public and department personnel. As such, every attempt will be made to limit Highway Department personnel to a maximum of 16 hours of snow removal operations at which time drivers will take a minimum six (6) hour break. In some cases (i.e., extreme weather conditions, declared snow emergency, or other emergency situations) it is possible that some drivers may exceed the time limits.

### *Annual Training*

The Highway Department may conduct an annual review and training session to cover snow removal policies and to review snowplow routes. If possible, snowplow drivers should drive their route prior to the winter season to observe any potential hazards that might hinder the snow removal process.

### **Damage to Private Property**

The Highway Department makes every effort to avoid damage to private property during the snow removal process. However, on occasion a piece of County snow removal equipment may damage private property located immediately adjacent to the roadway.

### **Motorists Responsibilities**

Motorists should limit their travel when hazardous conditions exist. If you must drive, motorists are advised to reduce their speed below the posted speed limits during adverse weather.

### *Highway Department Assistance*

It is the policy of the Marathon County Highway Department that no County equipment will be used to push, pull or tow a stranded, private vehicle from a roadway or ditch unless it is necessary to reopen a roadway or public travelway. In a life or health threatening situation, Highway Department personnel may provide assistance or call for emergency response. At no time will any Highway Department personnel use a County vehicle to perform any snow removal on private or commercial property unless in a life threatening or emergency situation.



## **Pavement Management**

Roadway pavement represents one of the largest infrastructure investments for the Marathon County Highway Department. Maintaining pavements throughout the County involves complex decisions about how and when to resurface or apply other treatments to keep the highway performing at acceptable levels and costs at a reasonable level. The Marathon County pavement management system consists of three major components:

1. A system to regularly collect pavement condition data.
2. A computer database to store and sort the data.
3. An analysis program to evaluate preservation and repair strategies to identify cost-effective solutions to maintain the County Highways.

### ***Purpose***

Critical decisions are made every day that affect the overall performance and operating costs of Marathon County roadways. Information from a pavement management system provides an effective way to achieve better performance with less cost by providing valuable information to the appropriate decision-makers about when and how to repair roadway pavement throughout the County. The purpose of a pavement management program is to maximize the life of the pavement while minimizing the cost of maintaining the roadways.

## ***Pavement Ratings***

The Marathon County Highway Department is required by Wisconsin law to record pavement condition data on a bi-annual basis. In compliance with this law, the Highway Department rates pavement conditions utilizing the Pavement Surface Evaluation and Rating (PASER) rating system.

PASER uses visual inspection to evaluate pavement surface conditions on a scale of 1 (reconstruction required) to 10 (new construction). **Figures 16 and 17** display the PASER pavement ratings. The key to a useful evaluation process is identifying different types of pavement distress and linking them to a cause. Understanding the cause for current conditions is extremely important in selecting an appropriate maintenance or rehabilitation technique.

### **Training Assistance**

Cities, Villages, and Townships are required by law to collect pavement condition data on a bi-annual basis. It is in the best interest of the local agencies and the County to use consistent pavement ratings to identify appropriate maintenance or reconstruction measures. If requested, the Marathon County Highway Department will provide cities, villages, and townships training regarding pavement condition ratings.



Figure 18. Pavement Condition Ratios (10 to 6)

<i>Surface rating</i>	<i>Visible distress*</i>	<i>General condition/ treatment measures</i>
<b>10</b> Excellent	None.	New construction.
<b>9</b> Excellent	None.	Recent overlay. Like new.
<b>8</b> Very Good	No longitudinal cracks except reflection of paving joints. Occasional transverse cracks, widely spaced (40' or greater). All cracks sealed or tight (open less than 1/4").	Recent sealcoat or new cold mix. Little or no maintenance required.
<b>7</b> Good	Very slight or no raveling, surface shows some traffic wear. Longitudinal cracks (open 1/4") due to reflection or paving joints. Transverse cracks (open 1/4") spaced 10' or more apart, little or slight crack raveling. No patching or very few patches in excellent condition.	First signs of aging. Maintain with routine crack filling.
<b>6</b> Good	Slight raveling (loss of fines) and traffic wear. Longitudinal cracks (open 1/4"-1/2"), some spaced less than 10'. First sign of block cracking. Slight to moderate flushing or polishing. Occasional patching in good condition.	Shows signs of aging. Sound structural condition. Could extend life with sealcoat.



Figure 19. Pavement Condition Ratings (5 to 1)

Surface rating	Visible distress*	General condition/ treatment measures
<b>5</b> Fair	Moderate to severe raveling (loss of fine and coarse aggregate). Longitudinal and transverse cracks (open 1/2") show first signs of slight raveling and secondary cracks. First signs of longitudinal cracks near pavement edge. Block cracking up to 50% of surface. Extensive to severe flushing or polishing. Some patching or edge wedging in good condition.	Surface aging. Sound structural condition. Needs sealcoat or thin non-structural overlay (less than 2")
<b>4</b> Fair	Severe surface raveling. Multiple longitudinal and transverse cracking with slight raveling. Longitudinal cracking in wheel path. Block cracking (over 50% of surface). Patching in fair condition. Slight rutting or distortions (1/2" deep or less).	Significant aging and first signs of need for strengthening. Would benefit from a structural overlay (2" or more).
<b>3</b> Poor	Closely spaced longitudinal and transverse cracks often showing raveling and crack erosion. Severe block cracking. Some alligator cracking (less than 25% of surface). Patches in fair to poor condition. Moderate rutting or distortion (1" or 2" deep). Occasional potholes.	Needs patching and repair prior to major overlay. Milling and removal of deterioration extends the life of overlay.
<b>2</b> Very Poor	Alligator cracking (over 25% of surface). Severe distortions (over 2" deep). Extensive patching in poor condition. Potholes.	Severe deterioration. Needs reconstruction with extensive base repair. Pulverization of old pavement is effective.
<b>1</b> Failed	Severe distress with extensive loss of surface integrity.	Failed. Needs total reconstruction.

\* Individual pavements will not have all of the types of distress listed for any particular rating. They may have only one or two types.



## **Pavement Analysis**

The Marathon County Highway Department utilizes the Wisconsin Information System for Local Roads (WISLR) to store and analyze pavement conditions. The PASER pavement ratings, as recorded by the Highway Department, are submitted to WisDOT and are recorded in WISLR. The WISLR program includes an evaluation program that analyzes current and future roadway and pavement conditions. The analysis part of the pavement management system helps forecast how long a pavement segment will last when certain repairs are performed under the given traffic loads, current road conditions, and other factors.

### **“Life Cycle” Maintenance Approach**

The Marathon County Highway Department uses a “life cycle” approach as opposed to a “worst first” maintenance approach. A “worst first” maintenance approach is one that fixes the poorest rated roadways / pavement first. A “life cycle” approach is one that focuses on extending the life of the pavement throughout the entire County. For example, rather than spending 50% of pavement maintenance on the poorest rated roadways the County might spend 20% to 25%. The money saved from less reconstruction can be used on higher rated roadways to extend their life. By consistently following this process the number of miles rated as poor will gradually decline as the pavement life increases.

### **Five-Year Needs Analysis**

The Highway Department utilizes the WISLR cost-benefit analysis to generate an annual list of priority pavement improvements for a five-year period. The Highway Department utilizes historical cost data for materials to estimate pavement maintenance for this period. It is important to note that the WISLR cost-benefit analysis is a tool used to prioritize projects.

Simply because a roadway project is identified as needed within a certain time period does not mean that it must be completed at this time. The Highway Department and Infrastructure Committee will use the WISLR data to help prioritize pavement maintenance and/or reconstruction projects. The combination of the pavement analysis tool, along with the local knowledge of the Highway Department and Infrastructure Committee, will lead to the efficient selection of roadway improvements throughout the County.

## ***Typical Maintenance Activities***

Typical pavement maintenance is tied directly to the pavement condition ratings. A typical Wisconsin pavement experiences extreme temperature ranging from sub-zero temperatures in the winter months to near 100 degree temperatures during the peak summer months. These extremes have significant impacts on roadway conditions. To best handle these conditions it is important to have a maintenance process in place.

A typical roadway pavement will require some maintenance approximately every five (5) years. Some roadways will require maintenance sooner while others may be longer. Much of this depends on traffic levels, traffic mix (i.e., passenger cars, heavy trucks, etc.)

**Figure 18** displays typical maintenance activities that the Marathon County Highway Department uses based on pavement conditions and ratings. Following this figure, a description of the maintenance activities is provided.





Figure 20. Typical Pavement Maintenance

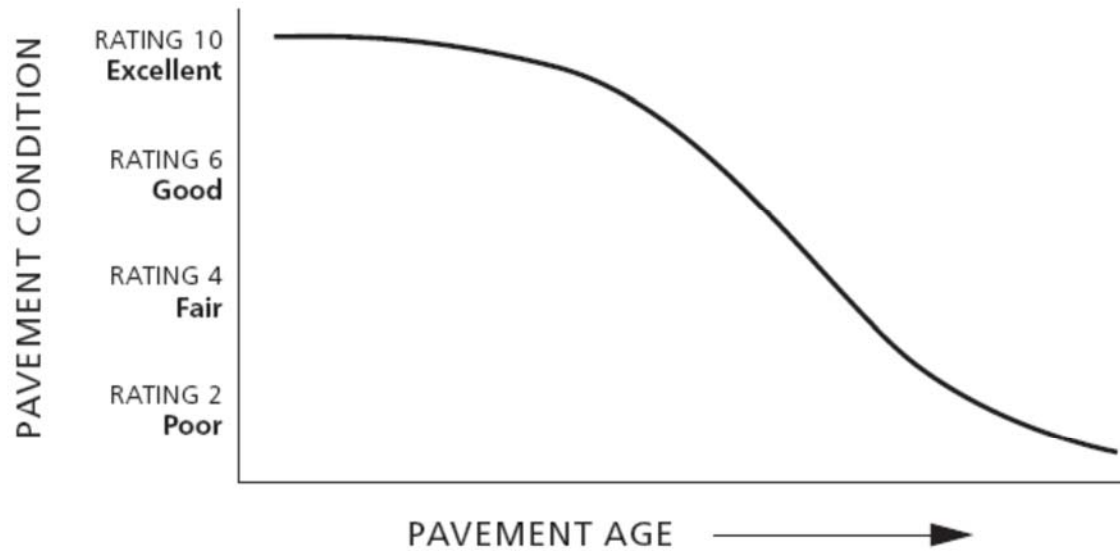

In addition to indicating the surface condition of a road, a given rating also includes a recommendation for needed maintenance or repair. This feature of the rating system facilitates its use and enhances its value as a tool in ongoing road maintenance.

**RATINGS ARE RELATED TO NEEDED MAINTENANCE OR REPAIR**

<b>Rating 9 &amp; 10</b>	No maintenance required
<b>Rating 8</b>	Little or no maintenance
<b>Rating 7</b>	Routine maintenance, cracksealing and minor patching
<b>Rating 5 &amp; 6</b>	Preservative treatments (sealcoating)
<b>Rating 3 &amp; 4</b>	Structural improvement and leveling (overlay or recycling)
<b>Rating 1 &amp; 2</b>	Reconstruction



### **Crack Sealing**

Crack sealing is the process of cleaning and sealing or resealing cracks in asphalt concrete pavements. This technique is used to fill longitudinal and transverse cracks, including joint reflection cracks from underlying concrete slabs, that are wider than 1/8 in. The primary purpose of crack sealing in asphalt pavements is to prevent surface water infiltration into the pavement foundation. It is more cost effective to use this technique as a preventative measure when the overall pavement condition is good or better. Sealing cracks in a deteriorated pavement is not cost effective. The technique consists of the following steps:

1. Remove old sealant and form a sealant reservoir. Use a vertical spindle router or hand tools.
  - Remove the loose material along edges.
  - The sealant reservoir depth should be at least the width of the crack plus ¼ in.
2. After routing, clean the crack using compressed air (do not sandblast).
3. Apply sealant. Do not overfill the crack; fill to 1/8 in. below the pavement surface.

### **Minor Patching**

Minor patching is the process of cleaning out and filling with bituminous patch material potholes in asphalt concrete pavements. This technique is used as a stop-gap maintenance for areas where the asphalt is cracked and broken to the point where a hole has formed. Pot holes can form because of severe cracking due to weather or material deficiencies or from normal traffic and plowing activities. Patches are also used as a result of utility repairs and pavement damage due to construction. The primary purpose for minor patching in asphalt pavements is to prevent surface water infiltration into the pavement

foundation and to prevent hazardous conditions for vehicles. The technique consists of the following steps:

1. Remove cracked and loose asphalt from inside the pot hole and around the edges.
2. After removing loose material, insert bituminous patching material, rake and compact to create a smooth surface.

### **Slag / Chip Seal Coating**

A seal coat (slag or chip seal) is one of many types of surface treatments used in road maintenance. A seal coat is an application of asphalt emulsion followed immediately with an aggregate cover. Seal coats can waterproof the surface, provide low-severity crack sealing, and restore surface friction. Seal coating can be performed at any time in the life of a pavement and lasts an average of three (3) to six (6) years.

The primary purpose of seal coating is to protect the street from deterioration caused by sun and water. A seal coat provides a waterproof membrane that keeps the pavement from becoming brittle and cracking, and also helps keep water from seeping through the pavement and causing problems to the base material.

### **Mill and Overlay**

There are several maintenance practices that involve milling. An edge mill typically consists of grinding the old bituminous surface along the outer 8 feet of the street. This helps establish a uniform cross-section, especially in instances where the crown in the street is relatively flat. A full width mill, or resurfacing, is necessary when the upper surface layer of pavement has deteriorated considerably. Significant surface pavement distresses and more extensive “thermal” cracking need to be removed and/or repaired with a full width and uniform



depth milling process. Both edge mills and full width mills are typically 1.5 to 2 inches thick, but can vary on a project by project basis.

Milling creates an even surface to ensure a uniform overall thickness to the new overlay. An asphalt overlay of 1.5 to 2 inches over the entire pavement width forms a smooth crown, renews the street surface, restores the structural capacity and proper drainage, and extends the life cycle of the original pavement.

A full depth mill can be used on a street that has already been reconstructed with a good base section, but the pavement has deteriorated to a point where the seal coating or a standard mill and overlay is not effective. A pavement section with significant cracking will end up reflecting through the new pavement. The full depth of the pavement is ground up and removed. This process may also involve some subgrade soil corrections and some removal of aggregate base, if it has been contaminated or is sub-standard. The street is paved with the same thickness of new asphalt.

Pavement can also be reclaimed, where approximately 8 inches of the existing asphalt and base are ground up in place. This forms a new more stable base without adding new material. The road is then paved with new asphalt. This is only recommended where there is no curb and gutter on the road, since the existing materials stay in place and a higher road elevation is created once the new pavement thickness is added.

### **Asphalt pulverizing**

Asphalt pulverizing is the process of breaking up the existing pavement and blending it in to the existing base. The new base is re-compacted, graded and made ready for new paving. Pulverizing is a very cost effective way to reconstruct your

existing pavement if no utility repairs are necessary and no grade modifications are needed. Consider asphalt pulverizing for a pavement that has failed and a mill and overlay is not a feasible option.

### **Cold In-Place Recycling**

Cold In-Place Recycling (CIR) is the process of milling and crushing the existing asphalt pavement, adding foamed asphalt or asphalt emulsion, and re-laying the mixture with a paving screed. A hot or warm mix surface layer is placed over the CIR layer. Consider CIR for highways that have adequate structures to support the CIR paving equipment and significant grade corrections are not required.

### **Reconstruction**

Reconstruction is generally required when a road has reached the end of its life cycle. When a road is fully reconstructed, the existing asphalt and base are completely removed and replaced. Reconstruction may also involve subgrade soil corrections. For roads that do not meet current design standards for width, curb and gutter, and drainage, an upgrade may also be incorporated.

### **Lane Wedging**

Lane wedging is a process using fine hot asphalt to fill in wheel ruts in the lanes. Normally this procedure is done on ruts greater than one inch on roadways not included in the five year program.

### **Liability**

The Marathon County Highway Department is not responsible for damage to vehicles caused by normal or routine maintenance activities.



**Shoulder Paving Policy**

For Pavement Replacement Projects, shoulders will typically be paved on Marathon County Highways according to traffic volumes, truck percentages and local conditions. County highways are typically paved according to widths illustrated in Table 1.

For Highways identified in the 2009 Wausau MPO Bicycle and Pedestrian Plan (see Table 3), the width of the paved shoulder will typically vary between three feet and five feet depending on local conditions. Table 2 lists guidance for using different paved shoulder widths.

Typically the pavement rehabilitation projects the County constructs do not include earthwork and ditch re-grading; therefore the width of the paved shoulder will be limited to the width of the existing roadbed.

County Highways not included in the 2009 Wausau MPO Bicycle and Pedestrian Plan (Table 3) may have paved shoulders constructed with Pavement replacement projects. The community would have to request in writing for the Department to pave the shoulders. The request should include justification for the additional infrastructure investment. If approved by the Department, the community would be responsible for sponsoring the additional work by funding 50% of the cost of the hot mix asphalt pavement (including material, equipment, labor and administrative costs).

A Memorandum of understanding (MOU) will be made between the Department and the community documenting the project; this MOU would also indicate that the community will be responsible for 50% cost share of the shoulder paving when the road is re-paved in the future.

**Table 1. Marathon County Highway Department Pavement Rehabilitation Standards**

Current Traffic	Design Traffic*	Design Speed	Traveled Way	Paved Shoulder**	Aggregate Shoulder	Total Road Width
(ADT)	(ADT)	(mph)	(feet)	(feet)	(feet)	(feet)
< 500	< 750	≥ 45	20	1	2	26
500-1500	750-2500	≥ 45	22	1	3	30
1500-2500	2500-3500	≥ 45	22	1+	5	34
≥ 2500	≥ 3500	≥ 45	24	3	3	36

\* Design Traffic is projected out 20 years at a growth rate of 1.5% to 2.5%.  
 \*\* May require engineering study to determine design criteria  
 + Shoulders may be paved at 3' – 5' width depending on local conditions.

**Table 2. Paved Shoulder Width Guidelines Bike/Ped Plan**

Width	Typical Application
3'	Roadway ADT of less than 1500, truck percentages of less than 5%, length of paved shoulder more than 2 miles, low population density.
4'	Roadway ADT less than 3500, truck percentages of less than 10%, medium density population.
5'	Roadway ADT more than 2500, truck percentages more than 10%, high density population, high recreational traffic generation (i.e. schools, daycare, etc.)

\*The criteria listed above are meant to be guidelines for the Department to use in determining paved shoulder widths; widths may vary depending on local conditions.



**Table 3. Paved Shoulders on County Highways**

Based on the Bike/Ped. Plan for the Non-Urbanized Area of Marathon County

<u>Community</u>	<u>Location</u>	<u>Miles</u>	<u>Location</u>	<u>Miles</u>
Birnamwood	CTH N, Village Line to CTH D	1	Other Areas	CTH O, CTH U to CTH A 4
Elderon	CTH C, Sunshine to STH 49	0.5		CTH A, CTH O to CTH K 4
Hatley	CTH Y, Konkol to STH 29	1		CTH K, CTH A to County Line 5
	CTH Y, STH 29 to CTH DD	1		CTH J, Martin Rod to CTH Q 2
Athens	CTH A, Village Line to Nehrbass	1.5		CTH Q, CTH J to STH 29 7
	CTH M, Village Line to Townline	1.5		CTH Y, Plover River to Shady Lane 1
Colby	CTH N, Village Line to Maple Rd.	1.75		CTH Y, Sportsman to Eau Claire River Road 1
Unity	CTH P, Village Line to Maple Rd.	1.75		CTH JY, County Line to Shantytown Dr. 1
Spencer	CTH V, County Line to Village Line	4.25	<u>Wausau Metro Area</u>	
	CTH C, Village Line to CTH F	1.75		CTH K, Hwy 51 to CTH A 4
Marshfield	CTH E, STH 97 to Turtle Ridge Rd.	3.5		CTH U, Hwy 51 to 44 <sup>th</sup> Ave. 1.75
	CTH AAA north to State 97	1		CTH X, Bull Junior Creek to STH 153 3.5
Stratford	CTH M, STH 153 to Fairview Rd.	1.5		CTH X, Northwestern Ave. to STH 52 4
	CTH C, STH 97 to pump station	3.5		CTH XX, Bus 51 to CTH X 1.75
	CTH M, CTH C to Oxbo	1		CTH J, Weston Ave. to CTH N 4
Fenwood	CTH M, CTH P to Blackberry	1.5		CTH N, Wausau City Limits to CTH X 2
Edgar	CTH H, STH 29 to CTH N	3		CTH Z, Wausau City Limits to CTH X 2
Marathon	CTH B, CTH N to Village Line	1		CTH W, Wausau City Limits to CTH WW east 3
	CTH NN, Village Line to CTH R	10		CTH WW, CTH K to CTH W 3.75
	CTH N, STH 107 to Thornapple Rd	6		CTH N, CTH KK to Red Bud Rd .5
				CTH R, Sherman St to CTH N 3.5
				CTH KK, CTH N to Burma 7
				CTH B, CTH KK to Mosinee City Limit 0.5
				CTH KK, CTH B to Burma Road 2.5

\*State roads listed above are from the County's Bicycle and Pedestrian Plan and are listed for informational purposes only; the County does not imply that any funding is anticipated for the State highways listed above.



## **Culvert and Bridge Program**

Bridges are a vital part of the County Highway System that directly impacts the traveling public. The functional loss of a bridge not only impacts mobility but may also reduce accessibility to area businesses, industries, and residential neighborhoods. The Marathon County Highway Department is responsible for the inspection and maintenance of approximately 420 County and Township bridges.

### ***Purpose***

The purpose of the Marathon County Highway Department bridge management program is to focus on efficient and effective proactive maintenance with the ultimate goal of extending the life of bridges within the County. Providing safe and secure bridges throughout the County is a priority.

### ***Inspection Process***

The Marathon County Highway Department is required by Wisconsin State Statute 82.08 to inspect bridges every other year. In compliance of this law, the Marathon County Highway Department conducts bridge inspections for County bridges during odd years and Township bridges during even years.

The following guidelines can be used to help determine whether a structure is considered a bridge or a culvert. Many structures have abutments, decks, and railings but are considered culverts. Please note that clear span is measured from abutment face to abutment face.

A bridge is defined as a structure that has a clear span of 20 feet or more. Bridges may be eligible for either County Bridge Aid or Federal Bridge Aid. If the structure has a clear span of

less than 20 feet it is considered a culvert and an inspection is not mandatory. Culverts are only eligible for County Bridge Aid.

### **Visual Inspections**

Bridge inspections and condition assessments are the first step in a bridge preventative maintenance program. The inspection process consists of a visual evaluation of the structure to determine what deficiencies, if any, exist. The inspections help provide direction with regard to potential maintenance or rehabilitation treatments but do not define specific treatments or actions. Given the unique details and conditions of each bridge, the Highway Department determines specific bridge repairs based on a case-by-case basis.

During the inspection process, a rating system is used to categorize bridge conditions and ultimately prioritize the maintenance, repair, or replacement of specific structures. **Figure 19** displays the bridge ratings used by the Marathon County Highway Department.

### **Bridge Maintenance**

Areas of maintenance around a bridge may include signage, waterways, approaches, substructures, superstructures, and the road deck. These areas have the potential of requiring either structural or nonstructural maintenance. Many non-structural maintenance treatments are low cost and directly contribute to extending the life of the bridge, when executed in regular intervals. Areas considered to be nonstructural maintenance include debris cleaning, sweeping, joint cleaning and repair, scupper or drainage cleaning, crack filling, deck patching, and guardrail repair.

It should be understood that bridges, like any infrastructure, will eventually need to be replaced. However, preventative



maintenance can extend the life of a bridge in structural and nonstructural areas. Nonstructural preventive maintenance can alleviate the need for structural preventive maintenance. Timing in these cases is of the utmost importance with savings benefits potentially reaching into the thousands of dollars per bridge.

Many agencies perform route maintenance including such actions as crack fillings and sealing, pothole fillings, overlays, checking bridge abutments, cleaning scuppers, checking joints and bearing pads, and painting. These principles of maintenance are generally accepted when applied towards highways and roads, so the same process is essentially applied toward individual bridges.

### **County Bridge Aid**

Wisconsin Statute 82.08 provides for county aid to construct or repair town culverts and bridges. The County Board, by resolution, restricts such county aid to structures equivalent to 48 inches or larger. All Marathon County municipalities participate in County Bridge Aid except for the Villages of Birnamwood, Dorchester, Elderon, Rothschild, Spencer, Unity and Weston and the Cities of Abbotsford and Colby.

### **Application Process**

Municipalities must submit their application by October 1<sup>st</sup> of the year prior to project construction. The Department will review projects in the fall and spring of the year. The Infrastructure Committee will approve the final project list during the April or May Committee meeting.

Municipalities must submit a petition form to the Marathon County Highway Department. Applicants should provide a map

and mileage to the nearest intersection, name of stream, section numbers, adjacent property owner or any additional information that will be of assistance in locating the structure. Municipalities are encouraged to submit their applications as early as possible to allow the Highway Department adequate time to review the application and complete any engineering work that may be required. Any late applications, which are accepted by the Infrastructure Committee, may be reimbursed in the following cycle.

### **Policy**

The Marathon County Highway Department practice is to have the Highway Commissioner or his designee review and size each culvert. The reviewer will meet with applicants beginning in May and notify them on the status of their application.

Municipalities completing projects with their own staff or contractors must submit a reimbursement request for half the repair cost by September 1<sup>st</sup>. The reimbursement is typically made in March of the following year.

Municipalities who request County forces to complete their projects do not need to submit reimbursement request, rather they will be billed for ½ of the cost of the project. The County will retain the reimbursement for ½ the cost of the project.

If the municipality completes the construction with their own staff or a contractor, then the municipality is responsible for permitting through the Wisconsin DNR, Army Corps of Engineers and any other necessary permits. Permitting for projects completed by County forces will be completed by Highway Department staff.

Final bridge inspections will be made by the Highway Department in early September to allow sufficient time to



include costs in the next budget. By September 1<sup>st</sup>, municipalities must submit financial records for all major work/purchases, actual bills (or legible copies) and proof of payment. The final inspections can include projects underway, but not yet completed, provided that the amounts are obligated by written contract.

Villages can be incorporated in the above format, if action is taken under 81.36(6) of the Statutes. Cities may be considered under 83.03 of the Statutes. The Marathon County Highway Department will provide engineering help at the initial recommendation. Please contact the Engineering Department at (715) 261-1809 for additional information.

### **Funding**

As per state statute 81.38(2) the municipality shall pay \$750 of the initial cost. The county shall pay all costs in excess of the initial \$750 up to \$1,500 on culverts equivalent to 48" or larger. The municipality and county shall 50-50 cost share on costs exceeding \$1,500.

Typically the cost of replacing or repairing culverts and bridges, including bridge decks, rails and approaches (not exceeding 100 feet in length) can be approved for funding.

Typical items denied for funding include real estate costs, work further than 100' from structure, work not approved by the County prior to installation, work not meeting Wisconsin DNR/DOT typical construction standards and structures that still have a useful life remaining. Additionally, bridge projects that are eligible for 80% federal funding are typically denied for County funding if they do not meet the requirements for replacement under the federal program.

### **County Bridge Aid on Federal Aid Projects**

County funding is available for half of the matching cost, provided the amounts are obligated by a written contract. For example: If you replace or make major renovations to a bridge under Federal/State Aid (80% Federal/State funding) the county would normally pay half of the remaining 20% (on the structure and 100 feet of the approach work). Beam Guard installation is not eligible for federal aid but is cost shared 50-50 between the county and municipality. To receive such County Aid, the municipality must have submitted a petition.

### **Concurrent Action**

Concurrent action is necessary when a Bridge or Culvert is a joint responsibility with another municipality (on a town boundary), unless there is a written agreement which supersedes 80.11(7) of the Statutes.

### **Appeal Process**

Members of the L.R.I.P. Committee make up a five (5) person board to make recommendations to Infrastructure Committee. The appeal committee consists of members of the bridge aid program.





**Figure 21. Bridge Sufficiency Ratings**

Code	Condition	Description
N	Not Applicable	
9	Excellent	
8	Very Good	No problems noted.
7	Good	Some minor problems.
6	Satisfactory	Structural elements are sound buy may have minor deterioration.
5	Fair	All primary structural elements are sound buy may have minor section loss, cracking, spalling or scour.
4	Poor	Advanced section loss, cracking, spalling or scour.
3	Serious	Loss of section, deterioration, spalling or scour have seriously affected primary structural components. Local failures are possible. Fatigue cracks in steel or shear cracks in concrete may be present.
2	Critical	Advanced deterioration of primary structural elements. Fatigue cracks in steel or shear cracks in concrete may be present or scour may have removed substructure support. Unless closely monitored it may be necessary to close the bridge until corrective action is completed.
1	"Imminent" Failure	Major deterioration or section loss present in critical structural components, or obvious vertical or horizontal movement affecting structural stability. Bridge is closed to traffic, but corrective action may put back in light service.
0	Failed	Out of service, beyond corrective action.



# Overweight/Oversized Vehicles

The Marathon County Highway Department requires permits for overweight, overwidth, overheight, and overlength vehicles. Wisconsin State Statutes dictate the requirements (please see Chapter 348 – Vehicles – Size Weight and Load; Chapter 349.86 – Miscellaneous Highway Provisions; and Chapter 349.83 – County Highway Jurisdiction).

## Purpose

The purpose of this section is to define overweight/oversized vehicles that will require a single trip permit for hauling within Marathon County. This requirement emphasizes safety for the traveling public and helps minimize the potential damage that might be caused to County Highways, traffic control devices, public utilities, and other infrastructure.

## Single Trip Permit

A Single Trip Permit is required for overweight, overwidth, and overlength vehicles in the following situations:

<u>Permit Item</u>	<u>Associated Information</u>
Overweight	Legal Maximum Weight – 80,000 pounds*
Seasonal Overweight	Must meet all criteria for single trip permit to be issued.
Overwidth	Legal Maximum Width – 8’ 6”
Overheight	Legal Maximum Height – 13’ 6”
Overlength	Legal Maximum Length – 70’ 0”

\*must have correct axle spacing to carry 80,000 pounds

Axle weights may not exceed 20,000 pounds.

## Permit Requirements

1. Permit requests are accepted by the Marathon County Highway Department during the following hours:
  - Monday – Wednesday, 7:00 a.m. to 3:30 p.m.
  - Thursday – 7:00 a.m. to Noon.
    - Permits for moves on Saturday, Sunday, or Monday, must be received by noon on the preceding Thursday.
    - Permits received after noon on Thursday may not be valid for use until Tuesday.
2. Permits must be submitted a minimum of 48 hours before the anticipated move.
3. Completed applications will typically be processed within two business days on loads under 100,000 pounds on routes without bridge crossings. Permits over 100,000 pounds, or those that involve bridge crossings, will be processed as expeditiously as possible depending on loadings.
4. Any permits for townships involving overweight loads on a town road that has bridges will require County approval for the bridge crossing. All loading information must be supplied for the crossing approval.
5. All boxes on the permit form must be completed (i.e., axle weights, spacing, route, etc.) and submitted to the Marathon County Highway Department. All permits must include a contact person that is available to answer questions.
6. Applications can be submitted in person, by mail, or by fax.



**Haul Routes**

The applicant is responsible for reviewing the haul routes to identify bridge crossings, box culvert crossings, ability to make corners, special traffic control needs, and any other concerns that exist along the proposed haul routes. For routes that are not on the County Trunk Highway System, the applicant should contact the local municipalities including WisDOT.

The applicant is responsible to notify the Marathon County Highway Department of any signs or other traffic control devices that might be impacted. Any signs that need to be removed will be completed by the Marathon County Highway Department. The applicant (mover) is responsible for coordinating traffic control with the Marathon County Sheriff's Department during sign removal.

**Applicant (Mover) Responsibilities**

*Insurance*

1. The applicant must provide a certificate of insurance. The certificate will be verified if the permit is to a private party.
2. The applicant must have the following insurance coverage:

<u>Insurance</u>	<u>Minimum Requirement</u>
General Liability	\$1,000,000
Professional Liability	(if applicable) \$1,000,000
Auto Liability	\$1,000,000
Excess Liability	(excess of General and Auto Liability) \$1,000,000
Workers Compensation	Statutory Limits (\$100,000 per person / \$500 per accident)

*Escort Vehicles*

In some cases, an escort vehicle may be required. This decision will be made on an individual permit basis. It is the responsibility of the applicant to provide an escort vehicle.

*Utility Conflicts*

Utility conflicts should be identified ahead of time and coordinated with the impacted utility.

*Costs*

Any costs associated with sign removal, and re-installation of the signs, are the movers responsibility. Permit fees are billed to the applicant on a monthly basis. Failure to pay the previous month's bill will result in the withholding of additional permits and may require payment with all new permit requests.

**Non-Compliance**

Applicants (movers) who do not comply with these requirements are subject to a \$500 penalty and may be denied future permits. The Marathon County Highway Department will also refer the issue to the appropriate agency for further investigation which could result in additional fines and/or restrictions against the applicant (mover). The applicant (mover) will also be responsible for any repair costs for any damage resulting from illegal hauling.



Maximum Gross Vehicle Weights – Sec. 348.15(3)(g)

Manure Hauling Permits

On September 23, 2014, the Marathon County Infrastructure Committee adopted option E of sec. 348.15 (9)(f)2.a is Wis. Statutes as provided by 2013 Wis. Act 377.

Option E: Adoption of this ordinance pursuant to Sec. 348.15 (9)(f)2.a. of Wis. Statutes (as provided by 2013 Wis. Act 377) means that the governing body of a municipality or county imposes on all highways or specified highways under its jurisdiction, the maximum single axle limits and maximum gross vehicle weight limits as established in Sec. 348.15 (3) (g) for all Category B implements of husbandry as defined in Sec. 340.01 (24) (a)1. b. (see Act 377). All implements of husbandry are required to comply with seasonal and special postings and any postings on highway bridges or culverts under Sec.349.16 of Wis. Statutes.

- County permits are only for roads under the County Highway Department jurisdiction and are not valid on State or Local municipality roads.
• There are no exemptions from seasonal and special weight postings and any postings on highway bridges or culverts.
• Failure of the operator of an overweight vehicle to have a permit in his or her possession shall constitute a violation of the ordinance and permit coverage does not apply.
• Permit forms are located on the Wisconsin DOT website; IOH http://www.dot.wi.gov/forms/docs/mv2582.doc
Ag CMV http://www.dot.wi.gov/forms/docs/mv2583.doc

Maximum gross vehicle weight limits Sec. 348.15(3)(g) http://docs.legis.wisconsin.gov/document/statutes/348.15(3)(g).pdf

(See table on right)

Figure 348.15 (3) (g):

Table with 8 columns: Distances in feet between foremost and rearmost axles of a group, 2 axles of a vehicle or combination of vehicles, 3 axles of a vehicle or combination of vehicles, 4 axles of a vehicle or combination of vehicles, 5 axles of a vehicle or combination of vehicles, 6 axles of a vehicle or combination of vehicles, 7 axles of a vehicle or combination of vehicles, 8 axles of a vehicle or combination of vehicles. Rows 4-57.

2011–12 Wisconsin Statutes updated through 2013 Wis. Act 380 and all Supreme Court Orders entered before Sept. 3, 2014. Published and certified under s. 35.18. Changes effective after Sept. 3, 2014 are designated by NOTES. (Published 9–3–14)



## Seasonal Weight Limits

Temporary seasonal weight limits are implemented on most of Marathon County's County Highways. The limits are implemented when the frost begins leave the roadbed. This results in roadbed soils being saturated and having less strength to hold up to repeated heavy loads. The postings are authorized by Chapter 349.16 of the Wisconsin Statutes.

Department staff monitors roadbed conditions for implementing and terminating these temporary weight limits. The dates for implementing the limits vary with weather conditions, however it is typical for the postings to be implemented in March and terminated in April or May.

Description of the weight limits postings and a map illustrating the location of the postings can be found in the General Driving Information section of the Department's Information Site at [www.co.marathon.wi.us/highway.asp](http://www.co.marathon.wi.us/highway.asp).

### **Purpose**

Impose special weight limitations on any such highway or portion thereof which, because of weakness of the roadbed due to deterioration or climatic conditions or other special or temporary condition, would likely be seriously damaged or destroyed in the absence of such special limitations.

## **Milk Haulers**

As established at the April 3, 2008 meeting of the Marathon County Infrastructure Committee, the Marathon County Highway will issue permits to vehicles transporting milk from the point of production to the nearest main unposted road, allowing legal loads only, as provided in SS 348.15(3)(c)(bg). The hauler shall work directly with the commissioner to establish the most direct route having the least impact on the county highways; the least impact route might not be the shortest route. This policy only affects county highways and does not exempt the hauler to haul over any posted bridge which they exceed the posted weight. The hauler shall pay one annual permit fee at the current rate. This permit must be reviewed and renewed annually.

## **Request for All Season Road**

Individuals, businesses, or municipalities occasionally request the seasonal weight limits be removed from a County Highway, making it an all season road. As established at the April 4, 2013 meeting of the Marathon County Infrastructure Committee, the Marathon County Infrastructure Committee will review each request for all season roads (roads without a spring seasonal weight restriction) on an individual case basis. Each request will be reviewed and a decision will be made based on an engineering analysis, benefit to the community it serves, cost and reimbursement from the party it serves.



## Wisconsin Frozen Road Law

Detailed information and current declaration regarding the Wisconsin Frozen Road Law can be found at;

<http://www.dot.wisconsin.gov/travel/truck/frozenroad.htm>

*Important things to know with respect to permits involving 98,000 pounds on 6-axles:*

- The Wisconsin Department of Transportation (WisDOT) is the only agency that may issue a “Raw Forest Products Permit (RS Permit) per Wis Statute 348.27(9m)(a)4.
- The RS Permit authorizes transport of “raw forest products” at gwv of 98,000 lbs on vehicles or vehicle combinations with six or more axles none of which may exceed the axle weights set in the statute.
- During the spring thaw period established by WisDOT highway maintenance engineers, the RS Permit is suspended on local roads, but the permit authorizes transport on the State Trunk Highway System and connecting highways as defined in state law. The authorized routes include numbered State and US routes except any Interstate route and any route marked as a “Business Route”\*\*. All “connecting highways” are marked as State or US routes.
  - Vehicles and vehicle combinations operating with the RS Permit may transport over “Class II” highways, but may not exceed posted limits for bridges or culverts.

- Local maintenance officials wishing to allow operation of vehicles hauling “raw forest products” on roadway within their jurisdiction may issue a “General Permit” per s.348.27(3). When operating under this permission, the permit must be carried on the vehicle, per s.348.28.

\*\* The sole exception is the highway signed as Business 51 between exit 171 and Grand Avenue in Rothschild because this roadway is still State maintained.



## TODS Program

---

### ***How Do I Get A Sign?***

First, you fill out an application and attach a check for installation fee(s) made payable to the Marathon County Highway Dept., 1430 West Street, Wausau, WI 54401

Your check will be returned if you do not qualify for a sign or there is insufficient room for your sign.

Marathon County will review your application. If you are approved, you will be responsible for the initial cost of manufacturing and installation, and replacement and repair of damaged sign(s).

Marathon County shall install the sign for a fee of \$300.00 per sign.

### ***What is a TOD Sign?***

TODS stands for Tourist Oriented Directional Sign. A picture of four TOD signs is on the next page of this manual. The signs are reflective blue, with reflective white letters, 6'x 9" (1 line) and 6'x 18" (2 lines). The signs can be erected on most County Trunk Highways at their intersections with another County Trunk Highway or a Town Road. TOD signs provide motorists with directional information for tourist related businesses, and activities.

### ***Will My Business Qualify for a Sign?***

- Open at least 8 hours/day, 5 days/week, for at least 3 consecutive months, with public restrooms and drinking water.
- Shall be of significant interest to the traveling public to the extent that 50% or more of its annual visitors and/or gross income are derived from outside the area.
- The following are examples of TODS Program businesses, services or activities: Antique Shop, Gift/Craft Shop, Boat Rental/Public Landing, Fish Farm, Game Farm, Campground, Art Gallery, Museum, Buildings with Historical Interest, Gas Stations, Restaurants, or Private/Public Buildings & Grounds, etc.

### ***Additional Rules Include:***

The business does not have direct access to a County Highway

The business must be within 5 miles of the County Highway.

TOD signs may be prohibited on some highways or in some areas depending on local ordinances, etc.

Businesses shall be maintained in a manner consistent with standards generally accepted for the type of business, service, or activity.

Have all required licenses and permits.

No logos on signs.



**How Much Does The Sign Cost?**

The TODS Program is designed to be self-funded. Applicant is responsible for the initial cost of manufacturing and installation, and replacement and repair of damaged signs. Installation costs are listed below:

**INSTALLATION FEE PER SIGN (in addition to sign cost):**

(Paid at the time of application. Check will be refunded if application is denied)

- TOTAL COST: . . . . 1 Sign . . . . . \$300**
- 2 Signs . . . . . \$600**
- 3 Signs . . . . . \$900**
- 4 Signs . . . . . \$1,200**

The sign life is estimated to be ten years.

All checks should be made payable to the Marathon County Highway Department.

Mail all fees and applications to:

Marathon County Highway Dept.  
 1430 West Street  
 Wausau, WI 54401

If you have any questions please call (715)261-1802

**The TODS Program**

1	JERRY'S BAIT SHOP
3	HISTORICAL SOCIETY
	BILL'S TROUT FARM 2
	ART MUSEUM 4





## **Snowmobiles and ATVs**

Snowmobiles and All Terrain Vehicles (ATVs) are popular recreational activities within Marathon County. The County includes over 780 miles of snowmobile trails many of which are also open to ATVs. While the large majority of snowmobile and ATV trips occur off County roads and outside the public right-of-way, there are times when these recreational vehicles must cross a County highway. As such, the Highway Department shall review all highway/trail crossing locations throughout Marathon County.

### ***Purpose***

The purpose of this section is to summarize the proper use of snowmobiles and ATVs along, or across, Marathon County highways and roads. A primary concern of the Marathon County Highway Department is to maximize safety for the traveling public, including snowmobile and ATV riders.

### ***Snowmobile and ATV Rules***

The Marathon County Ordinance outlines specific rules and regulations for snowmobile and ATV riders within the County. Sections 7.09 and 7.13 outline the regulations regarding snowmobile trails and snowmobiles. Section 7.125 outlines the specific operation of ATVs. This section is intended to highlight the use of these vehicles as they impact the County Highway system. This section of the manual is not intended to take the place of the detailed rules and regulations that are outlined in the Marathon County Ordinance.

### **Snowmobile Coordinator**

For specific information regarding snowmobile or ATV travel within the County, please contact:

Marathon County Snowmobile Coordinator  
212 River Drive, Suite 2  
Wausau, Wisconsin 54403-5476  
(715) 261-1550

For up-to-date Marathon County trail conditions, please call the 24-hour snow condition hotline at 1-888-948-4748 or 715-355-8788.

### **Snowmobile Season**

The "snowmobile season" is determined by the snowmobile coordinator and will vary depending on weather conditions.

### **Snowmobile and/or ATV Route**

A highway or sidewalk designated for use by snowmobile and/or ATV operators adopted and signed by the respective township or club.

### **Snowmobile Trail**

A marked route on public or private property, subject to public easement or lease, designated for use by snowmobile operators by the Marathon County Snowmobile Coordinator, but excluding highways except those highways on which the roadway is not normally maintained for other vehicular traffic by the removal of snow.



### **Liability**

It is the responsibility of snowmobile and ATV riders to be familiar with and to observe all Marathon County Ordinances and regulations that relate to the use of recreational vehicles within the County. The Highway Department, and Marathon County, assumes no liability as to trails, machines, or individuals.

### ***Snowmobile and ATV Use of Highways***

The Marathon County Ordinance outlines the specific rules and regulations for snowmobile and ATV travel within Marathon County. Some of these rules directly impact travel along and across Marathon County highways. Rules impacting highway use are generally summarized in the following.

*Please note that the following is not intended to be a complete list of the snowmobile and ATV rules. All snowmobile and ATV riders are encouraged to review the complete rules and regulations prior to using the Marathon County snowmobile and ATV trails.*

1. Under most circumstances, snowmobiles and ATVs are not allowed to operate on any highway or road (with the exception of defined or acceptable highway crossings). At no time are snowmobiles and ATVs allowed to operate on any part of a freeway or interstate unless the WisDOT authorizes such use.
2. ATVs may operate on segments of County Highway if the segment of highway is an approved and properly signed route. Typical usage is for connecting segments of legal

ATV trails via short segments of low volume County Highways (typically less than 400 vehicles per day). Section 7.125 of the Marathon County Code of Ordinances allows for these segments of County Highway to be used for ATV use if approved by the Marathon County Highway Department. ATV user groups are required to formally apply for use, execute a written agreement with Marathon County and provide funding for establishing and maintaining the ATV route on the County Highway.

3. Snowmobile and ATV riders are encouraged to use designated trails and highway crossings. Snowmobile crossings can cause significant roadway damage if crossing areas are not properly maintained. Riders can directly cross any roadway having fewer than 5 lanes, but only after stopping and yielding the right-of-way to all vehicles approaching on the roadway. Crossings should be made only at a place where no obstruction prevents a quick and safe crossing.<sup>1</sup> Please see **Figure 20** for trail crossing information.
4. Recreational riders may use any roadway which is not normally maintained for other vehicle traffic by the removal of snow.
5. Unless it's prohibited and posted by the road's maintaining authority, you can ride on the roadway of highways to cross a bridge, culvert or railroad right-of-way, but only after yielding the right-of-way to all vehicle traffic.
6. Recreational riders may ride on the roadway of county or town highways and city or village streets for authorized

<sup>1</sup> "Obstruction" includes, but is not limited to impairment of view and potentially hazardous roadway conditions.



snowmobile events such as races or derbies (authorized under § 350.04, Wis. Stats.)



### **Use Along County Highways**

Snowmobiles and ATVs may be operated adjacent to a roadway, on a designated trail, with due regard to safety in the following manner:

1. At a distance of ten or more feet from the roadway along U.S. numbered highways and state and county highways. Travel on the median of a divided highway is prohibited except to cross.
2. Outside of the roadway along town highways.
3. During hours of darkness in the same direction as motor vehicle traffic in the nearest lane, although during daylight hours travel may be in either direction regardless of the flow of motor vehicle traffic.
4. Snowmobiles traveling adjacent to a roadway shall observe roadway speed limits.

### **Highway Crossings**

All crossings of State and County highways and roads shall be coordinated with the Marathon County Snowmobile Coordinator and approved by the Marathon County Highway Department.

All crossings of State and County highways and roads shall be coordinated with the Marathon County Snowmobile Coordinator and approved by the Marathon County Highway Department.

***Any maintenance cost to maintain a positive water flow due to any obstruction caused by the trail or trail grooming shall be the responsibility of the snowmobile and/or ATV club.***

### **Traffic Signs**

The Marathon County Highway Department shall be authorized to properly sign snowmobile and ATV trail crossings on County Trunk roads according to the State regulations, signing only those crossings deemed necessary by the Highway Department. No person shall intentionally remove, deface, or destroy any traffic control signs legally placed by the state, any municipality, Marathon County Highway Department, or the by Marathon County Snowmobile Coordinator. Any costs, including installation costs, will be the responsibility of the snowmobile clubs.

### **Exceptions**

Snowmobiles and ATVs may be operated for emergency purposes on any highway during a period of emergency when so declared by the governmental agency having jurisdiction.

Public utilities may at times use snowmobiles or ATVs to effectively carry out their obligations to the public. The restrictions summarized in this section relating to use on, or adjacent to highways, shall not apply. However, snowmobiles and ATVs operated by public utilities must be operated in a safe manner at all times.

For Snowmobile Trail Maps call the Marathon County Parks Department Office at 715-261-1550, visit the Park Administrative Office at 212 River Drive, Suite #2, or go to the Department's Information Site at

<http://www.co.marathon.wi.us/infosubtop.asp?dep=25&tid=41>

Figure 22. Highway / Trail Crossings

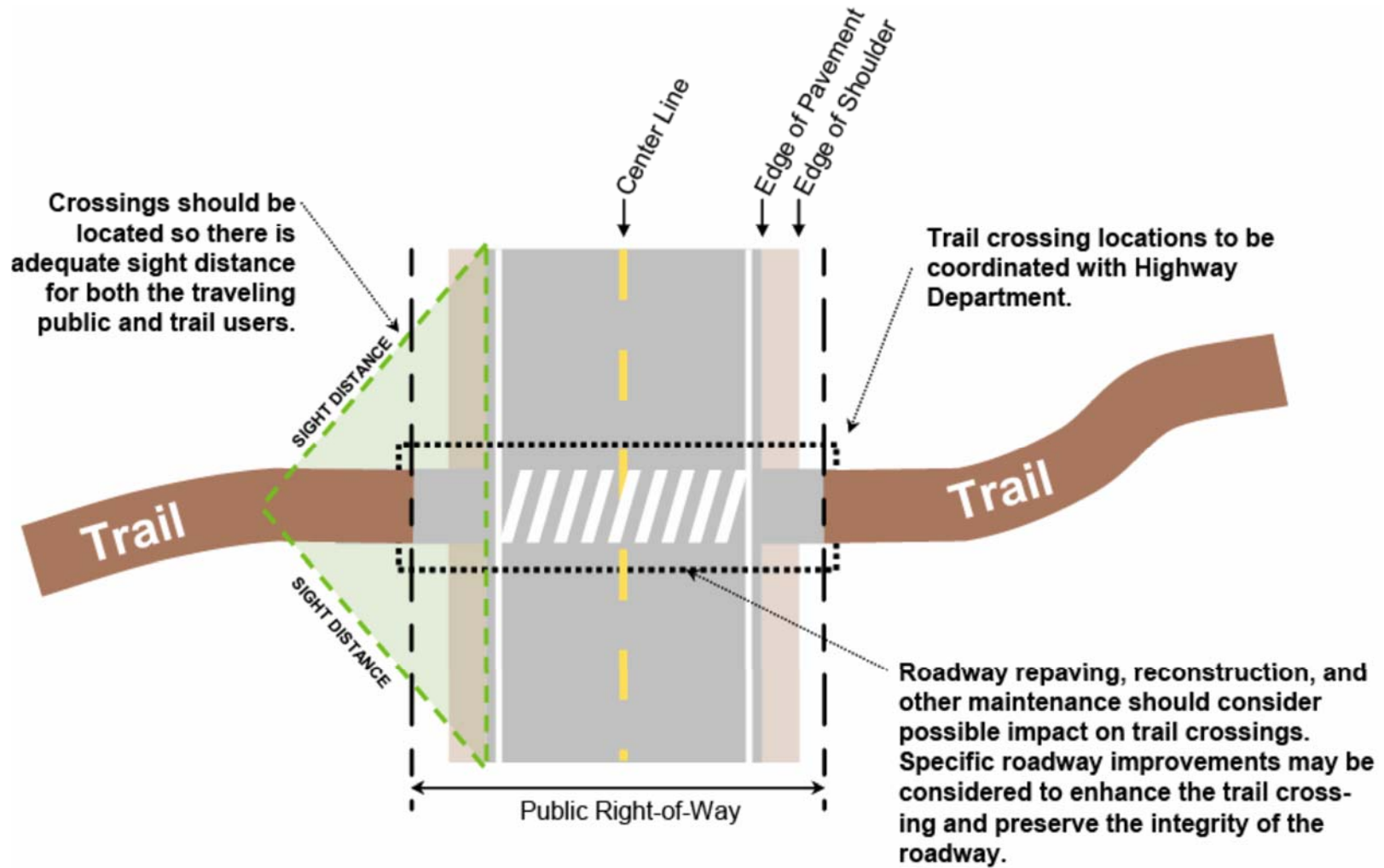



## Signing and Safety

### **Manuals for Uniform Traffic Control Devices**

The Marathon County Highway Department inventories and updates County signs according to the guidelines set forth in the Federal Manual for Uniform Traffic Control Devices (MUTCD) that also has a Wisconsin supplement. Sign reflectivity standards are addressed in these manuals along with various other sign regulations including colors, sizes, and types.

The Federal MUTCD manual is located at:  
<http://mutcd.fhwa.dot.gov/index.htm>

Wisconsin MUTCD supplement locations include:  
<http://www.dot.wisconsin.gov/business/engserv/wmutcd.htm>  
[http://mutcd.fhwa.dot.gov/resources/state\\_info/wisconsin/wi.htm](http://mutcd.fhwa.dot.gov/resources/state_info/wisconsin/wi.htm)

**Sign reflectivity brochure:**  
[http://epdfiles.engr.wisc.edu/pdf\\_web\\_files/tic/bulletins/Bltn\\_023\\_Retorelectivity.pdf](http://epdfiles.engr.wisc.edu/pdf_web_files/tic/bulletins/Bltn_023_Retorelectivity.pdf)

### **Sign Requests**

Regulatory sign requests (add/remove/change) need to be sent to the Highway Department in writing along with justification for the request along with specifics such as the days of week and times of day that a concern is occurring. Changes are not made merely because of personal preference. The Highway Department utilizes engineering guidelines and MUTCD manuals in determining any needed signing modifications.

Further details are found in the Wisconsin Statutes, the MUTCD manuals, as well as, other engineering guidelines and principles.

**Wisconsin §346.57** – Speed Restrictions:  
<http://legis.wisconsin.gov/statutes/Stat0346.pdf>

**Wisconsin §349.11** – Setting Speed Limits:  
<http://legis.wisconsin.gov/statutes/Stat0349.pdf>

Setting speed limits on local roads **bulletin** can be found at:  
[http://epdfiles.engr.wisc.edu/pdf\\_web\\_files/tic/bulletins/Bltn\\_021\\_Spe ed.pdf](http://epdfiles.engr.wisc.edu/pdf_web_files/tic/bulletins/Bltn_021_Spe ed.pdf)

Non-regulatory sign requests (i.e. “Watch for Children”) also need to be sent in writing after the local unit of government has weighed in on the request as the requestor typically pays for the cost to install and maintain these types of signs billed through the local unit of government if the request is granted. The Highway Department also utilizes engineering guidelines and MUTCD manuals in granting these requests.

### **Intersection Control**

Intersection crashes on the County Highway system will be reviewed annually. Intersections found to have developed a pattern of crashes involving failure to yield at a stop sign controlled intersection will be investigated further by the Highway Commissioner or the Commissioner’s designee. If the reviewer determines the frequency or severity of crashes at a particular intersection is significant, the intersection will be further investigated by surveying/inspecting the intersection and reviewing the crash reports.



The intersection survey/inspection will include, but is not limited to, the following items:

- Visibility of approach from all directions
- Location of existing signs
- Conformity of sign to Uniform Traffic Control Device Manual requirements (i.e. size, height, etc.)
- Condition of signs
- Pavement condition (i.e. bare, ice covered, ruts, etc.).

The crash reports will be reviewed to determine:

- What caused the crashes
- Did crash occur due to failure to stop?
- Did crash occur due to failure to yield upon leaving the "stop" location?

Based on the review of the intersection and the crash reports, the following countermeasures may be implemented:

- Double Stop signs
- Double Stop Ahead signs
- Larger than standard signs
- Install flags on the signs
- Four-way Stop signs
- Reduced speed on approaching highway
- Relocation of all signs (to avoid visual clutter, blending into background, make signs more prominent, etc)

Rumble strips will be considered if the use of any or all of the above fails to significantly reduce the frequency and/or severity of the crashes, or if deemed necessary due to the frequency and severity of crashes at an intersection.

Prior to installing rumble strips at a new location the following shall occur:

- Marathon County Highway Safety Commission will review the intersection and provide a recommendation to the Infrastructure Committee.
- A public meeting or public hearing will be held.
- The Marathon County Infrastructure Committee will make the final decision regarding the installation of rumble strips at any .

**Notes:**

1. Existing rumble strips will be replaced at intersections when the roadways are reconstructed. Permanent rumble strip removal must be approved by the Infrastructure Committee.
2. Rumble strips can be an effective means of alerting the public to an upcoming potential hazard when other means have failed to achieve a reduction in accidents. To be truly effective, rumble strips need to be used only in those locations determined to be unusually hazardous. Care needs to be taken to prevent drivers from relying on rumble strips to indicate that a stop sign is coming up. With limited installation, the rumble strips will immediately alert the motorist to the hazardous situation they will be encountering.

Rumble strips will typically be installed as illustrated in Figure 23. In special situations, thermoplastic rumble strips, as illustrated in Figure 24 may be installed. The thermoplastic material does have higher initial installation costs as well as more maintenance costs compared to milled in rumble strips.



Figure 23. Rumble Strip Layout

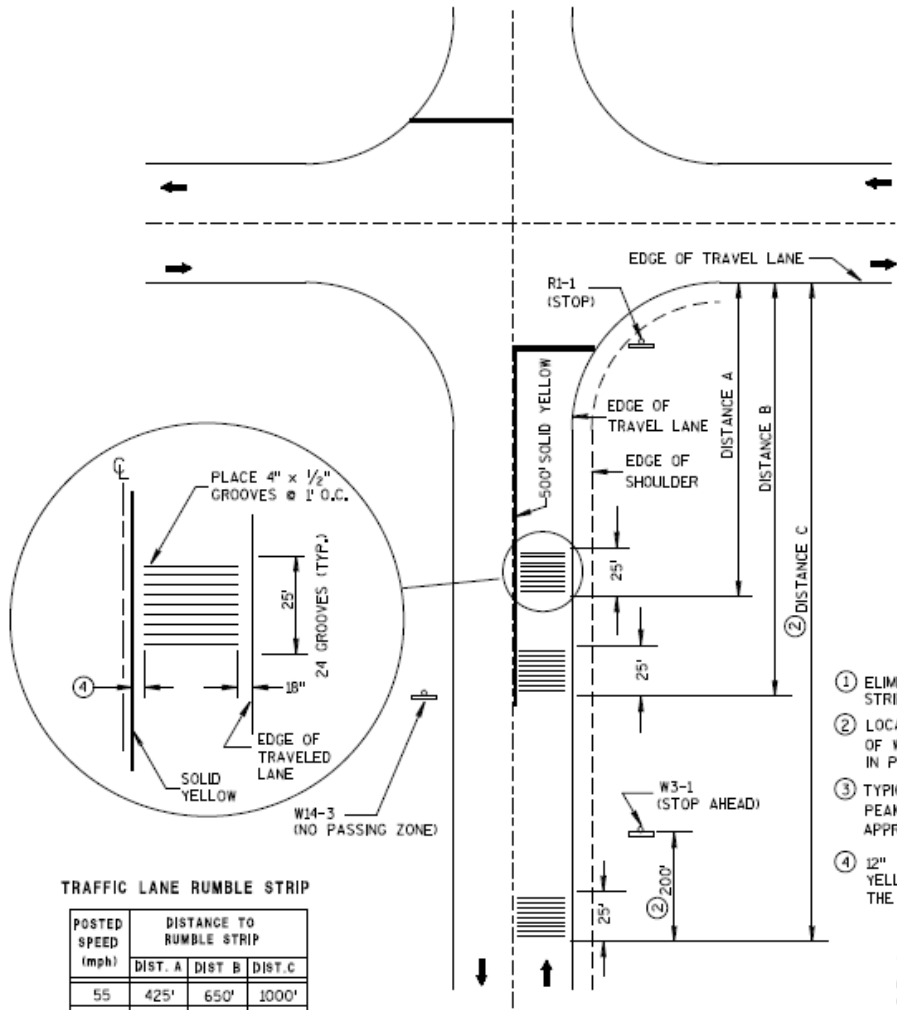

TRAFFIC LANE RUMBLE STRIP

POSTED SPEED (mph)	DISTANCE TO RUMBLE STRIP		
	DIST. A	DIST. B	DIST. C
55	425'	650'	1000'
50	325'	450'	800'
45	275'	400'	650'
40	225'	①	550'
35	175'	①	475'
≤ 30	125'	①	425'

ARROW SYMBOL (→) SHOWS DIRECTION OF TRAVEL  
PLAN VIEW  
RUMBLE STRIP LOCATION

- ① ELIMINATE THE MIDDLE SET OF RUMBLE STRIPS.
- ② LOCATE RUMBLE STRIP 200' IN ADVANCE OF W3-1 SIGN AS SHOWN, IF W3-1 IS NOT IN PLACE, USE DISTANCE C.
- ③ TYPICAL VERTICAL VARIATION BETWEEN PEAKS AND VALLEYS WITHIN THE CUT APPROXIMATELY 1/16"
- ④ 12" CLEAR BETWEEN THE SOLID YELLOW LINE AND THE EDGE OF THE RUMBLE.

GENERAL NOTES

CONTRACTOR SHALL CONFIRM RUMBLE STRIP LOCATION WITH THE ENGINEER PRIOR TO INSTALLATION. THE ENGINEER MAY MODIFY THE RUMBLE STRIP LOCATION AS FIELD CONDITIONS DICTATE.

WHEN ASPHALTIC PAVEMENT IS NEW IN THE RUMBLE AREA THE CONTRACTOR SHALL ALLOW THE PAVEMENT TO CURE A MINIMUM OF 7 DAYS PRIOR TO RUMBLE INSTALLATION.

PAVEMENT MARKING AND SIGNING DETAILS AND SPECIFICATIONS ARE PROVIDED ELSEWHERE IN THE CONTRACT.

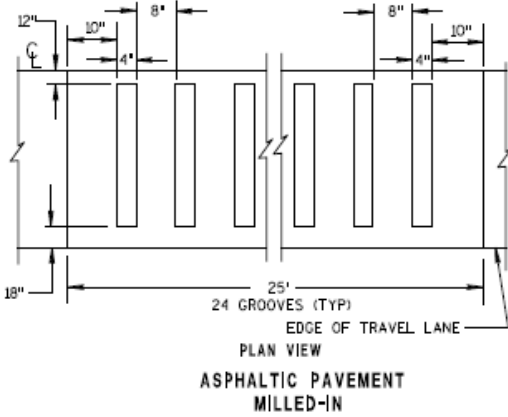
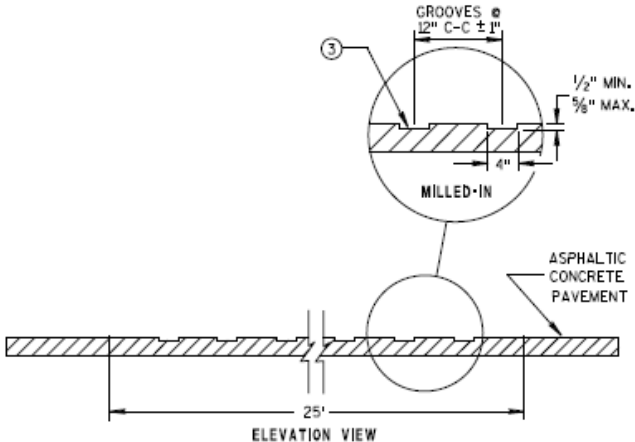

ASPHALTIC RUMBLE STRIPS AT INTERSECTION	
STATE OF WISCONSIN DEPARTMENT OF TRANSPORTATION	
APPROVED 8/17/2001 DATE	/s/ JEFF H. ZOGG ROADWAY STANDARDS DEVELOPMENT ENGINEER
DWG#	



Figure 24. Rumble Strip Layout (Thermoplastic)

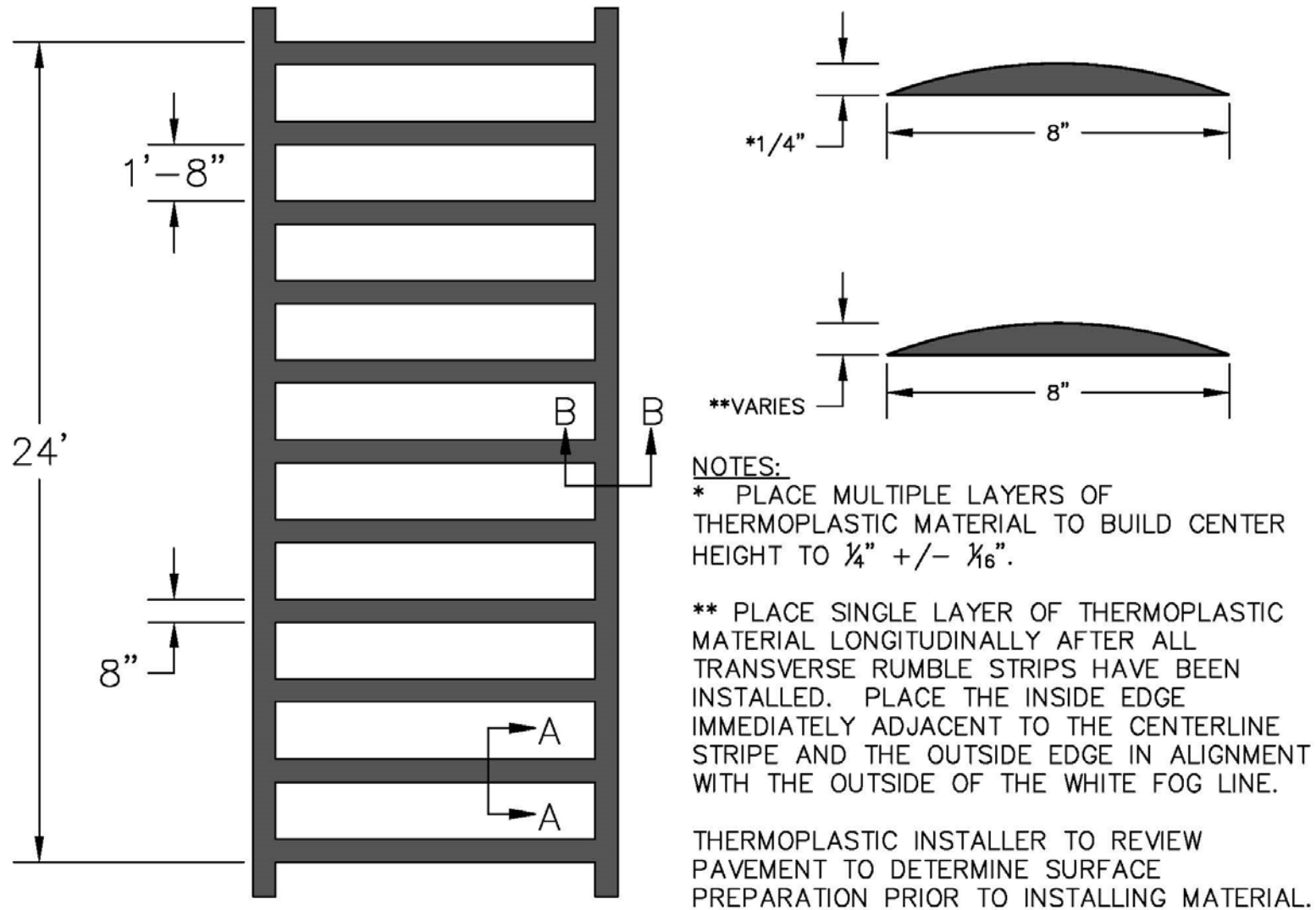



## **Work Zone Safety**

Experience has shown that following the principles and procedures developed and documented for proper temporary traffic control in the MUTCD manuals enhance the safety and communication in work zones. These principles and guidelines are utilized to the best of the Highway Department's ability to ensure the most safe and practical environment for both workers and the traveling public.

### **No Handheld mobile devices in work zones**

Wisconsin Act 308 was passed in an effort to reduce distracted driving and increase safety for motorists and workers throughout the state. This law makes it illegal to talk on a handheld mobile device while driving in a Wisconsin road work zone. Violators are subject to \$40 fines for the first offense and \$100 fines for subsequent offenses.

Remember - **fines double in work zones.**

**Helpful work zone resources** can be found at:

<http://www.dot.wisconsin.gov/business/rules/docs/wzsb.pdf>

<http://www.dot.state.wi.us/travel/road/workzones.htm>

<http://www.ops.fhwa.dot.gov/wz/>

<http://safety.fhwa.dot.gov/wz/>

<http://www.ops.fhwa.dot.gov/wz/resources/publications/publications.htm>

<http://www.dot.wisconsin.gov/safety/motorist/workzones/>

<http://www.dot.wisconsin.gov/travel/road/workzones.htm>

## **Safety Apparel**

Worker visibility personal protective safety clothing is intended to provide conspicuity (to make readily visible) during both daytime and nighttime usage, and also needs to meet the Performance Class requirements standards established by the

American National Standards Institute/International Safety Equipment Association (ANSI/ISEA).

Because standards for minimum reflectivity has changed over the years, Marathon County Highway Department uses the most current MUTCD manuals available as a resource in updating our safety apparel. Field guides provide industry standards established. We are able to select the proper classification of safety vests and apparel from these guides.

The Federal safety apparel brochure can be found at:

<http://safety.fhwa.dot.gov/wz/fhwasa03009/>



## Miscellaneous Items

---

### ***Procurement***

The Highway Department follows the procurement procedures established by Marathon County.

### ***Cooperative Agreements***

The Marathon County Highway Department may enter into cooperative work agreements with surrounding counties concerning projects, equipment, and operations.

### ***Work for Municipalities***

Municipalities, villages, and townships will be charged for any work performed by the Marathon County Highway Department.

### ***Brush Pick-Up***

The Marathon County Highway Department does not provide brush pick-up service.

### ***Dust Control during Construction***

The Marathon County Highway Department does not typically provide dust control for Town roads that motorists use to drive around road construction on County Highways. In the event a County Highway is routed onto a Town road with a signed detour for a project lasting four days or more, the Highway Department will evaluate the need to provide dust control.

### ***Vegetation***

Marathon County Highway Department typically mows the “top round” of roadways for vision purposes by or around July 4<sup>th</sup>. A second “top round” is typically targeted for the beginning of September. More frequent mowing may be needed depending upon the growing season and safety issues.

Vegetation management procedures for roadways under the jurisdiction of WisDOT follow the [Wisconsin Department of Transportation Highway Maintenance Manual](#) (User ID and password needed). The Manual provides guidelines for mowing and may be modified for safety and by WisDOT staff as needed.

### **Noxious Weeds**

The Department strives to kill all noxious weeds within the County ROW upon discovery.

Under [Wisconsin §66.0407](#) – Noxious weeds are defined as Canada thistle, leafy spurge, field bindweed, any weed designated as a noxious weed by the department of natural resources by rule, and any other weed the governing body of any municipality or the county board of any county by ordinance or resolution declares to be noxious within its respective boundaries.



## **Marathon County Invasive Species BMPs**

Marathon County Highway Department strives to manage Invasive species as a part of normal routine maintenance activities by following the Best Management Practices (BMPs) listed below;

### **Vegetation management & Inspection/Monitoring BMPs**

- Mow early to prevent seed production and to deplete root reserves.
- Avoid mowing/disturbing areas with known invasive species that are post-flowering stage and seeds are present.
- Limit transport of invasive species by cleaning mowers to the extent practical; increased cleaning should occur when the operator mows an area known to contain invasive species.
- Monitor right-of-ways during the growing season and determine treatments based on the known presence of invasive species.

### **Soil Disturbing Activities and Moving of Materials** (soil, trees, woody vegetation, etc.)

- Prior to implementing activities scout for and locate invasive species infestations.
- Plan activities to limit the potential introduction and spread of invasive species, minimizing impact to areas known to contain invasive species.
- Inspect and clean as necessary all equipment, clothing, footwear and gear for soils, seeds, plant parts, or invertebrates before and after activities to the extent practical.
- Select appropriate species and materials for re-vegetation and landscaping activities.

- Re-vegetate disturbed soils as soon as feasible to minimize invasive species establishment.
- Minimize movement of materials known to contain invasive species and properly dispose of materials containing invasive species.

### ***Invasive Species resources:***

<http://council.wisconsinforestry.org/invasives/transportation/>  
<http://dnr.wi.gov/invasives/>

### ***Disclaimer***

*This manual was prepared to summarize the policies and procedures of the Marathon County Highway Department. It is intended to convey the Highway Department procedures that relate to or directly impact the County Highway system. Please note that many sections in this manual reference specific laws, rules, and regulations including, but not limited to, the Wisconsin State Statutes and Marathon County Ordinances. This manual is not intended to be a substitute for the specific laws and regulations contained in the Statutes, Ordinances, or any other documents.*

*The Marathon County Highway Department, and Infrastructure Committee, reserves the right to review and revise the policies and procedures in this manual. The Highway Department also reserves the right to make decisions on a case-by-case basis regarding issues that are not contained in this manual.*



## Miscellaneous Transportation Related Links

### Road Salt Storage:

<http://www.dot.wisconsin.gov/business/rules/salt-storage.htm>

### Road Sensors:

<http://www.dot.wisconsin.gov/travel/stoc/sensors.htm>

### Roadway Standards:

<http://roadwaystandards.dot.wi.gov/standards/index.htm>

<http://roadwaystandards.dot.wi.gov/standards/stnds-spec/index.htm>

### Round-A-Bouts:

<http://www.dot.wisconsin.gov/safety/motorist/roaddesign/roundabout.htm>

### Rules of the Road:

<http://www.dot.wisconsin.gov/safety/motorist/rules/>

### Scales:

<http://www.dot.wisconsin.gov/about/locate/sp/scales.htm>

### Studies:

<http://www.dot.wisconsin.gov/projects/index.htm>

### Traffic Counts:

<http://www.dot.wisconsin.gov/travel/counts/index.htm>

### Truck Routes:

<http://www.dot.wisconsin.gov/travel/maps/truck-routes.htm>

### Uninsured Motorists:

<http://www.dot.wisconsin.gov/drivers/drivers/traffic/sr-requirements.htm>

### Vehicles Miles Traveled (VMT):

<http://www.dot.wisconsin.gov/travel/counts/vmt.htm>

### Waysides & Rest Areas:

<http://www.dot.wisconsin.gov/travel/restareas/>

### WisDOT Organizational Structure & Contacts:

<http://www.dot.wisconsin.gov/about/structure/index.htm>

<http://www.dot.wisconsin.gov/about/contacts/index.htm>

<http://www.dot.wisconsin.gov/about/contacts/phoneguide.htm>

[http://165.189.80.128/sowdir/directory\\_online.asp](http://165.189.80.128/sowdir/directory_online.asp)

[http://wi.gov/state/core/sowdir/directory\\_search.asp](http://wi.gov/state/core/sowdir/directory_search.asp)

### WisDOT Six-Year Programs:

<http://www.dot.wisconsin.gov/projects/state/sixyear/index.htm>

### WisDOT Videos:

<http://www.youtube.com/user/wisdot>



## List of Wisconsin Statutes and Administrative Rules

- [Chapter 30](#) Navigable Streams
- [Chapter 32](#) Eminent Domain
- [Chapter 59](#) Counties
- [Chapter 66](#) Sub-Chapter IX public works & Projects
- [Chapter 66.0301](#) Intergovernmental Cooperation
- [Chapter 66.0627\(1\)](#) Special Charge on Tax Bill
- [Chapter 66.0407](#) Noxious Weeds
- [Chapter 66.1031](#) Widening of Highways
- [Chapter 66.1033](#) Curative Provisions
- [Chapter 66.1035](#) Rights of Abutting Owners
- [Chapter 66.1037](#) Beautification & Protection
- [Chapter 66.1003](#) Discontinuance of a Public Way
- [Chapter 82](#) Town Highways
- [Chapter 82.03\(1\)\(a\)](#) Town Hwys-“Passable”
- [Chapter 82.05\(3\)](#) Town Hwys-Passable a-s-as-practical
- [Chapter 83](#) County Highways
- [Chapter 83.42](#) Rustic Roads
- [Chapter 84](#) Trunk Highways (State)
- [Chapter 85](#) WisDOT
- [Chapter 86](#) Miscellaneous Highway Provisions
- [Chapter 86.02](#) Misc. Hwy Prov – Injury to Highway
- [Chapter 86.03\(1\)](#) Removal of Fallen Trees
- [Chapter 86.04](#) Highway Encroachments
- [Chapter 86.06](#) Highways Closed to Travel; Penalties
- [Chapter 86.105](#) Contract for Snow Removal
- [Chapter 88.68](#) Construction/Drains Across Highways+
- [Chapter 88.87](#) Road Grades not to obstruct drainage
- [Chapter 88.89](#) Roads not to obstruct watercourse
- [Chapter 91](#) Farmland Preservation-Ownership
- [Chapter 101](#) Dept. of Commerce-Variou Regulations
- [Chapter 102](#) Workers Compensation
- [Chapter 103](#) Employment Regulations
- [Chapter 106](#) Equal Rights
- [Chapter 108](#) Unemployment
- [Chapter 295](#) Non-Metallic Mining
- [Chapter 342.40](#) & [346.94\(13\)](#) Removing Vehicles
- [Chapter 343](#) Operators’ Licenses
- [Chapter 343.05\(4\)](#) CDL – Exemptions
- [Chapter 345.05](#) Municipal liability for vehicle accidents\*\*
- [Chapter 346.05](#) Exceptions to driving on the right
- [Chapter 346.072](#) Passing stopped highway machinery
- [Chapter 346.27](#) Persons working on highway
- [Chapter 346.51](#) Stopping, standing, parking outside business
- [Chapter 346.57](#) Speed Restrictions
- [Chapter 346.915](#) Snowplow following distances
- [Chapter 346.94\(5\)](#) Injurious substance on hwy (snow)
- [Chapter 346.95](#) Penalties for debris on hwy (snow)
- [Chapter 347.45\(2\)](#) Prohibited Tire Equipment
- [Chapter 348](#) Vehicle Size, Weight & Load
- [Chapter 349](#) Local Authority-Vehicle Powers
- [Chapter 349.11](#) Setting speed limits
- [Chapter 349.15](#) Modify Weight Limits & Classify Roads
- [Chapter 349.16](#) Special/Seasonal Weight Limits
- [Chapter 893.83](#) Claims Against Gov’ts – Hwy Defects\*\*
- [Chapter 943.01](#) Damage to Property



## **Highway Administrative Code and Rules of Relevance**

### COMMERCE

- [COMM 8](#) Mines, Pits & Quarries
- [COMM 32](#) Public Employee Safety & Health
- [COMM 45](#) Mechanical Refrigeration

### DEPARTMENT of WORKFORCE DEVELOPMENT

- [DWD Chapter 80](#) Workers Compensation (WC)
- [DWD Chapter 81](#) WC – Treatment Guidelines
- [DWD Chapter 82](#) WC – Mining Damage Claims
- [DWD Chapter 290](#) Public Works (PW) Contracts
- DWD Chapter 290 PW Contracts - [Appendix A](#)
- [DWD Chapter 293](#) PW Payment & Performance Assurance
- [DWD Chapter 294](#) PW Debarment Contractors

### DEPARTMENT of NATURAL RESOURCES

- [NR 102](#) Water Quality Standards for Surface Waters
- [NR 135](#) Non-Metallic Mining Reclamation
- [NR 151](#) Run-off Management
- [NR 40](#) Invasive Species
- [NR 300](#) Time Limits/Fees re: Waterway Permit+
- [NR 320](#) Bridges & Culverts-Navigable Waterways
- [NR 341](#) Grading-Banks of Navigable Waterways
- [NR 345](#) Dredging Navigable Waterways
- [NR 350](#) Wetland Compensatory Mitigation

- [TRANS RR1](#) Rustic Roads
- [TRANS 200](#) Erection Signs on Public Highways
- TRANS 200 Signs – [Appendix A](#) - Spec. Info. Sign Hwys
- TRANS 200 Signs – [Appendix B](#) - Service (B/W) Signs
- TRANS 200 Signs – [Appendix C](#) - TODS Signs
- TRANS 200 Signs – [Appendix D](#) – Gen. Dir. Guide Signs
- [TRANS 202](#) Wisconsin Scenic Byways
- [TRANS 204](#) Town Road Standards
- [TRANS 205](#) County Highway Standards
- [TRANS 206](#) LRIP
- [TRANS 207](#) Bridges & Culverts
- [TRANS 213](#) Local Bridge Program
- [TRANS 214](#) Town Road Bridge Standards
- [TRANS 220](#) Utility Relocation
- [TRANS 230](#) Permits for Oversize/Overweight Loads
- [TRANS 231](#) State Highway Driveway Permits
- [TRANS 250](#) Oversize & Weight (OS/OW)–Size & Weight
- [TRANS 276](#) OS/OW - Vehicles & Combinations
- [TRANS 278](#) OS/OW - Exceptions
- [TRANS 277](#) Salt Storage
- [TRANS 280](#) Roadside Vegetation Management
- [TRANS 307](#) Standards for Load Securement
- [TRANS 510](#) TEA Program
- [TRANS 515](#) Contractual Service Procurement

### TRANSPORTATION – Administrative Codes







## **Appendix A**

---

# **MARATHON COUNTY TRANSPORTATION POLICIES AND PROCEDURES PLAN**

---

Prepared for

Marathon County Department of Conservation, Planning and Zoning and Highway Department

## **Review of Best Practices Technical Memorandum #3**

Prepared by  
URS Corporation  
October 2007

### ***Introduction***

This memo includes:

- A review of best practices focusing on pavement management and bridge management.



## **Overview of Asset Management**

Public agencies across the Country are faced with many challenges including increasing costs (i.e., gasoline, materials, etc.) and limited funding resources. During these times, residents, businesses, and other stakeholders expect transportation professionals to manage transportation assets in an effective, efficient, and reliable manner. Asset management is an approach that can help in this process. Simply stated, asset management is a process that helps ensure the proper use and performance of the transportation assets. Asset management maximizes the use of public resources, provides accountability, and emphasizes on-going preservation of the transportation infrastructure. The philosophy, and benefits, of asset management include the following:

- 1) **Preservation first approach** – Asset management programs encourage the preservation of your infrastructure. It is more cost-effective to perform regular maintenance on pavement and bridges as opposed to letting these assets deteriorate to a point where reconstruction or replacement is required. In the long run, a public agency will save money by performing regular, routine maintenance that extends the life of valuable transportation assets.
- 2) **Moving from a “worst first” to “life cycle” approach** – Asset management programs recognize it is better to prioritize and spend money on pavement and bridges in “good” condition as opposed to simply spending the majority of a budget on pavement and bridges in “poor” condition and in need of major repairs or reconstruction. Agencies using the “worst first” approach will be in a constant state of catch-up as there will be reduced or limited funding to maintain good roadways and bridges and as a result, facilities in “good” condition deteriorate at a faster rate. Agencies that use a “life cycle” approach, aimed at preserving infrastructure in good condition, are in a better position to meet the overall maintenance and reconstruction needs of the community.
- 3) **Creditability with stakeholder and the public** – Asset management programs provide creditability to the decision making process. A pavement and bridge management program provide an objective analysis of the infrastructure conditions by prioritizing projects based on current conditions, projected future conditions, and budget limitations. From this, a prioritized list of projects is generated which will ultimately help in identifying the most cost-effective projects. Asset management programs are a valuable tool to aid in the decision making process; however, they are just that – a tool. It is important to understand that asset management programs do not replace the decision making process. Instead, asset management programs help elected officials, transportation officials, and staff arrive at the most efficient and effective solutions to preserve, maintain, and maximize the use of very valuable transportation resources.

The two most common elements of asset management are a pavement management program and bridge management program which are discussed in the following sections.



## ***Pavement Management Program (PMP)***

Various pavement management programs are available to help counties, municipalities, and local agencies in collecting, storing, and analyzing pavement condition data. While these programs vary in format, the general goal of a pavement management program (PMP) remains the same – to identify the most cost-effective way to preserve pavement in a good, safe, and serviceable condition for the traveling public.

### **Current Practice**

The Marathon County Highway Department is required by Wisconsin Law to collect pavement condition data (pavement ratings) on a bi-annual basis. The Highway Department currently rates pavement using the Pavement Surface Evaluation and Rating (PASER) methodology. PASER uses a 1 to 10 rating system to evaluate surface distress, skid characteristics, pavement strength and deflection, and roughness of ride. A roadway with a rating of "1" represents the poorest conditions as this pavement surface would show visible signs of distress and extensive loss of surface integrity. A roadway in this condition is failing and in need of a total reconstruction. At the opposite end of the rating system, a rating of "10" indicates the pavement surface is in excellent condition, displaying no visible signs of distress, and is likely new or very close to new construction.

Once the Marathon County Highway Department rates the roads, the data is submitted to the Wisconsin Department of Transportation (WisDOT) where the data is entered in a database called the Wisconsin Information System for Local Roads (WISLR). Local agencies, including the Marathon County Highway Department, are able to access WISLR to obtain pavement rating data in addition to other roadway specific characteristics such as construction date, construction materials, maintenance history, and average daily traffic volumes. WISLR is able to consider all of this data to identify appropriate maintenance, reconstruction, and funding needs. WISLR generates a five-year plan of priority projects based on current and projected funding levels. The Marathon County Highway Department has previously utilized WISLR to review pavement condition ratings but has not frequently used the program to aid in scenario planning and project prioritization.

### **Pavement Management Plans/Programs**

Many local agencies have adopted a PMP to assist in the preservation and on-going maintenance of roadway pavement. A very basic PMP consists of rating roadway pavements and identifying the worst pavement for repair or reconstruction. However, the greatest benefit of a PMP is when the ratings are collected, entered into a computer database, and then evaluated to identify appropriate system-wide maintenance, repair, and reconstruction projects.



Many computer software programs are available to assist local agencies and decision makers in storing and evaluating pavement conditions. Regardless of the software, the concept is basically the same; to assist decision-makers in finding cost effective strategies for evaluating and maintaining pavement in a reliable, safe, and serviceable condition. A PMP generally consists of two basic components:

1. A comprehensive database, which contains current and historical information on pavement condition, pavement structure, and traffic demands.
2. A set of software tools that allow evaluation of alternatives, determination of existing and future pavement conditions, identification and prioritization of pavement renovation projects, and prediction of financial needs necessary to accomplish goals.

The first step in implementing a PMP is to determine an appropriate field inspection and pavement rating process. Given that Wisconsin law requires the submittal of pavement condition data to WisDOT, and that WisDOT uses the PASER pavement rating system, the continued use of the PASER rating system is in the best interest of the Marathon County Highway Department.

The goal of the rating process is to produce a pavement condition index (PCI) value that represents pavement conditions as observed in the field. The PCI values are based on various factors including type of roadway distress, distress severity, and distress quantity present in the pavement surface. The PASER PCI values are illustrated in Table 1.



**Table 1. PASER Pavement Rating Categories and Typical Treatment Measures**

Surface Rating		Visible Distress	General Condition / Treatment Measures
10	Excellent	None	New construction
9	Excellent	None	Recent overlay, like new.
8	Very Good	<ul style="list-style-type: none"> <li>➤ No longitudinal cracks except reflection of paving joints.</li> <li>➤ Occasional transverse cracks, widely spaced (40' or greater).</li> </ul>	<ul style="list-style-type: none"> <li>➤ Recent sealcoat or new road mix.</li> <li>➤ Little or no maintenance required.</li> </ul>
7	Good	<ul style="list-style-type: none"> <li>➤ Very slight or no raveling, surface shows some traffic wear.</li> <li>➤ Longitudinal cracks (open 1/4") spaced due to reflection or paving joints.</li> <li>➤ Transverse cracks (open 1/4") spaced 10 feet or more apart, little or slight crack raveling.</li> <li>➤ No patching or very few patches in excellent condition.</li> </ul>	<ul style="list-style-type: none"> <li>➤ First signs of aging.</li> <li>➤ Maintain with routine crack filling.</li> </ul>
6	Good	<ul style="list-style-type: none"> <li>➤ Slight raveling (loss of lines) and traffic wear.</li> <li>➤ Longitudinal cracks (open 1/4" - 1/2") due to reflection and paving joints.</li> <li>➤ Transverse cracking (open 1/4" - 1/2") some spaced less than 10 feet.</li> <li>➤ Slight to moderate flushing or polishing.</li> <li>➤ Occasional patching in good condition.</li> </ul>	<ul style="list-style-type: none"> <li>➤ Show signs of aging, sound structural condition.</li> <li>➤ Could extend life with sealcoat.</li> </ul>
5	Fair	<ul style="list-style-type: none"> <li>➤ Moderate to severe raveling (loss of lines and coarse aggregate).</li> <li>➤ Longitudinal cracks (open 1/2") show some slight raveling and secondary cracks. First signs of longitudinal cracks near wheel path or edge.</li> <li>➤ Transverse cracking and first signs of block cracking. Slight crack raveling (open 1/2").</li> <li>➤ Extensive to severe flushing or polishing.</li> <li>➤ Some patching or edge wedging in good condition.</li> </ul>	<ul style="list-style-type: none"> <li>➤ Surface aging, sound structural condition.</li> <li>➤ Needs sealcoat or non-structural overlay.</li> </ul>
4	Fair	<ul style="list-style-type: none"> <li>➤ Severe surface raveling.</li> <li>➤ Multiple longitudinal and transverse cracking with slight raveling.</li> <li>➤ Block cracking (over 25 - 50% of surface).</li> <li>➤ Patching in fair condition.</li> <li>➤ Slight rutting or distortions (1" deep or less).</li> </ul>	<ul style="list-style-type: none"> <li>➤ Significant aging and first signs of need for strengthening.</li> <li>➤ Would benefit from recycling or overlay.</li> </ul>
3	Poor	<ul style="list-style-type: none"> <li>➤ Closely spaced longitudinal and transverse cracks often showing raveling and crack erosion.</li> <li>➤ Block cracking over 50% of surface.</li> <li>➤ Some alligator cracking (less than 25% of surface).</li> <li>➤ Patches in fair to poor condition.</li> <li>➤ Moderate rutting or distortion (1" or 2" deep).</li> <li>➤ Occasional potholes.</li> </ul>	<ul style="list-style-type: none"> <li>➤ Need patching and major overlay or complete recycling.</li> </ul>
2	Very Poor	<ul style="list-style-type: none"> <li>➤ Alligator cracking (over 25% of surface).</li> <li>➤ Severe distortions (over 2" deep).</li> <li>➤ Extensive patching in poor condition.</li> <li>➤ Potholes.</li> </ul>	<ul style="list-style-type: none"> <li>➤ Severe deterioration.</li> <li>➤ Need reconstruction with extensive base repair.</li> </ul>
1	Failed	<ul style="list-style-type: none"> <li>➤ Severe distress with extensive loss of surface integrity.</li> </ul>	<ul style="list-style-type: none"> <li>➤ Failed.</li> <li>➤ Needs total reconstruction.</li> </ul>



Pavement Life Cycle

A critical concept in understanding the importance of a PMP is that it is better to spend money on a regular basis to preserve and extend the pavement life by performing regularly scheduled routine maintenance as opposed to letting the pavement deteriorate to a state where reconstruction is required. In terms of dollars, for every \$1.00 spent to maintain pavement in “good” condition will require approximately \$4.00 spent if the pavement is allowed to deteriorate to a “poor” condition. Simply stated, an agency that applies lower cost preventative maintenance measures will likely extend the pavement life of a roadway and ultimately save money in the long term.

Monitoring a pavement’s life cycle indicates that the cost of pavement rehabilitation for every one mile of road in very poor condition is roughly the same as the cost for renovation/rehabilitation of four miles of road in fair or better condition. Ultimately, it is more cost effective to rehabilitate/repair a road before the PCI ratings drop too far below a five (5).

Pavement Deterioration Curve

Studies conducted by a number of agencies indicate that as pavement conditions decrease, the cost for the appropriate method of repair can quadruple. A graph of a typical case taken from the American Public works Association, The Hole Story, is shown in Figure 1.

Figure 1. Pavement Life Cycle Costs

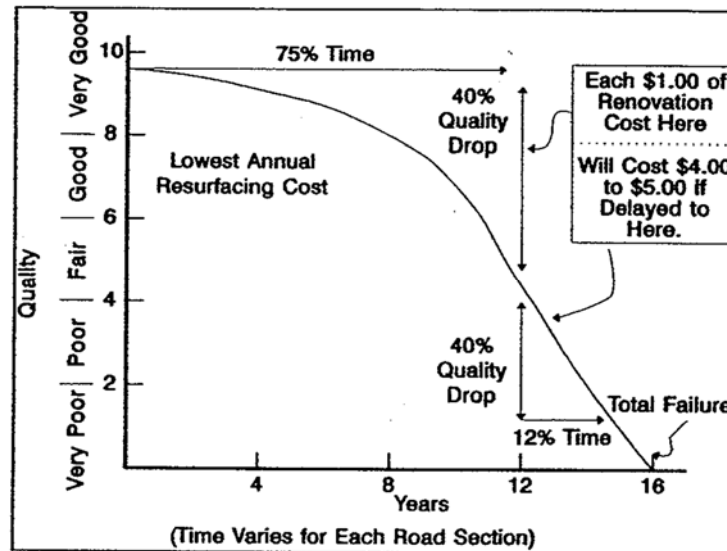



The pavement deterioration curve demonstrates that the most cost effective method of extending the surface life of most asphalt pavement surfaces is to concentrate spending on surface treatments and repairing/rehabilitating roads before they deteriorate too far. In general, if one can service the road before the PCI drops much below five (5), it is more cost effective.

Conversely, once the PCI drops near or below three (3), it may be more cost effective to allow a road to continue to deteriorate until funding is available for a complete reconstruction. This may be a difficult decision to make, particularly to residents that live along such a roadway, but when faced with the responsibility of stretching limited maintenance funds for the greatest public good, this may be a necessary decision. In considering the situation just mentioned, if a limited resource of funds can reconstruct two or three miles of badly deteriorated roadway, or the money can be spent to preserve 15 to 25 miles of road in good condition, then in the long run performing routine maintenance and preserving the roadways will eventually benefit the entire County from both an operational and cost perspective.

Pavement Rejuvenation/Sealing Strategy

One strategy the County Highway Department has used, and should continue to use, is a pavement rejuvenation/preventive maintenance strategy (seal coating). In order to preserve the surface of good roads, and help them remain “good” for a longer period, preventive maintenance is the most cost effective method to protect this important infrastructure investment. This method is commonly referred to as “pay me now, or pay me later”, with the philosophy that pavement rejuvenations every five to seven years for “good” local roads for 20 years is much cheaper than complete rehabilitation. Essentially, at approximately a five to seven year cycle, local roads that are near a pavement rating of 5 and 6 will be treated with a rejuvenating seal coating to preserve and protect the pavement surface. Figure 2 illustrates an example of a pavement rejuvenation treatment process.

**Figure 2. Example of Pavement Rejuvenation Treatment Cycle**

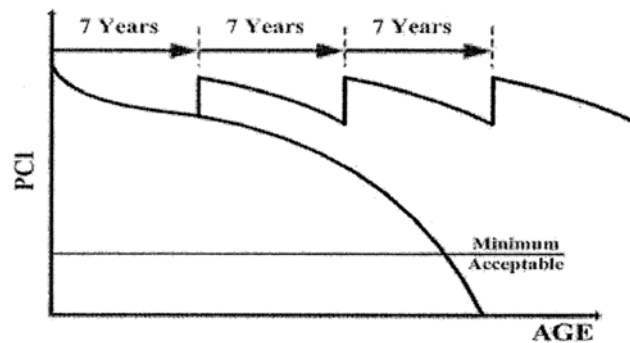



As demonstrated by the declining curve in Figure 2, a pavement left untreated will gradually reach a PCI that drops below the minimum acceptable. By comparison, a roadway that receives regular maintenance (treated every seven years in this example) is more likely to remain in a “good” condition and maintain a higher PCI. In the end, the routine maintenance extends the life of the roadway and ultimately reduces the overall maintenance and reconstruction costs.

An economic analysis of this strategy versus traditional road overlay strategy is summarized in Table 2. Alternative A assumes a regular maintenance program that includes a total of five seal coat treatments and one overlay resulting in a pavement life of 48 years. The total estimated cost of these activities is approximately \$3.90/s.f. By comparison, alternative B has no regular, routine maintenance and is removed and replaced twice during the same 48 year time frame. The total cost of this alternative is estimated at approximately \$20.00/s.f. While both alternatives provide the same pavement life, alternative B is more than four times the cost of alternative A. Furthermore, alternative A is less disruptive to the traveling public and provides a higher and more consistent PCI which translates into a smoother ride for the traveling public.

**Table 2. Comparison of Maintenance Scenarios**

Alternative A			Alternative B		
Description of Maintenance	Years	Cost Estimate	Description of Maintenance	Years	Cost Estimate
3 Seal Coat Treatments	24	\$1.20/sf	2 Remove and Replace	48	\$20.00/sf
1 Overlay	8	\$1.90/sf			
2 Seal Coat Treatments	16	\$0.80/sf			
<b>TOTAL</b>	<b>48</b>	<b>\$3.90/sf</b>	<b>TOTAL</b>	<b>48</b>	<b>\$20.00/sf</b>

**Future Action**

There are several advantages to continue using PASER and WISLR for pavement management within Marathon County. PASER has been previously used by the Highway Department to perform pavement ratings so this is a very familiar process and future data collection will be consistent with previous pavement ratings. Opportunities to enhance the PMP exist with greater use of the WISLR program. Specifically, the Highway Department should take advantage of the planning, financial analysis, and prioritization features that are contained within WISLR. The advantages of continuing to use both PASER and WISLR are summarized below:





- 1) WisDOT requires pavement condition ratings to be submitted by the County and the PASER rating system (1 to 10 rating) is what is used in the WISLR program. Adopting a different rating system (for example, a 1 to 100 rating), which other pavement software programs may require, would add significant time and costs, and in essence would be duplicating the pavement rating process.
- 2) WISLR is free of charge to Wisconsin counties, municipalities, and local agencies. Other pavement management software can be expensive to purchase and maintain.
- 3) WISLR is maintained and supported by WisDOT. Existing features are constantly reviewed and improved while new features are added to provide local agencies better resources in making sound, cost-effective decisions. WISLR also allows local agencies to control the quality of the data, to map data and view its location, and also provides direct access to WisDOT forms, maps, and reports.
- 4) WISLR contains an evaluation tool, or scenario planning feature, that allows public agencies to consider funding, cost of materials, and future pavement conditions to help identify priority improvements over a five-year time frame. The funding analysis can be based on recent funding levels or “what if” scenarios can be run to see how more or less funding will impact the pavement conditions throughout the county.
- 5) The information contained in WISLR is based on extensive research data obtained on pavement conditions in Wisconsin and the Midwest. As a result, the maintenance/reconstruction recommendations are based on local conditions and are not unrealistic conditions. For example, pavement condition data collected in warmer parts of the country will not have the same characteristics as roadway pavement located in the State of Wisconsin.

Ultimately, the PMP is aimed at finding cost effective strategies for evaluating and maintaining pavement in a reliable, safe, and serviceable condition. The Marathon County Highway Department should continue to use PASER to collect the pavement condition data and should further utilize WISLR to help in the planning and budgeting process.

### ***Bridge Management Program (BMP)***

Bridges are a vital part of the County Highway System that directly impacts the traveling public. The functional loss of a bridge not only impacts mobility but may reduce accessibility to area businesses, industries, and residential neighborhoods. Similar to the PMP, bridge management programs (BMP) are available to assist decision makers in identifying and prioritizing bridge maintenance, repair, and reconstruction. Generally speaking, the same basic principals of a PMP apply to a BMP – to identify the most comprehensive, cost-effective way to preserve bridges in a reliable, safe, and serviceable condition for the traveling public.



### **Current Practice**

The Marathon County Highway Department is required by Wisconsin State Statute 84.17 to inspect bridges every other year. In compliance of this law, the Marathon County Highway Department conducts bridge inspections for County bridges during odd years and Township bridges during even years. In total, the Marathon County Highway Department is responsible for the inspection and maintenance of approximately 420 bridges.

A bridge is defined as a structure that has a clear span<sup>2</sup> of 20 feet or more. Bridges may be eligible for either County Bridge Aid or Federal Bridge Aid. If the structure has a clear span of less than 20 feet it is considered a culvert and an inspection is not mandatory. Many structures have abutments, decks, and railings but are considered culverts.

Marathon County bridge inspectors are required to be state-licensed. The inspectors collect inventory data and condition information in the field on system-generated pre-inspection reports and enter the inspection results into an electronic format to comply with National Bridge Inspection (NBI) standards. Their inspections are based on the American Association of State Highway and Transportation Officials "AASHTO Guide for Commonly Recognized (CoRe) Structural Elements" and custom developed elements that provide information on the condition of each element on the bridge.

### **Preventative Maintenance**

Bridges, like all infrastructure, will eventually require reconstruction or replacement. However, preventative maintenance can extend the life of a bridge in structural and nonstructural areas. Nonstructural preventive maintenance can alleviate the need for structural preventive maintenance. Timing in these cases is of the utmost importance with savings benefits potentially reaching into the thousands of dollars per bridge.

Many agencies perform route maintenance including such actions as crack filling and sealing, pothole fillings, overlays, checking bridge abutments, cleaning scuppers, checking joints and bearing pads, and painting. These maintenance principles are generally accepted when applied towards highways and roads, so the same process is essentially applied toward individual bridges. The Marathon County Highway Department performs preventative maintenance on a case-by-case basis as different bridges may have unique characteristics and maintenance requirements.

---

<sup>2</sup> The clear span is measured from abutment face to abutment face.



Areas of maintenance around a bridge may include signage, waterways, approaches, substructures, superstructures, and the road deck. These areas have the potential of requiring either structural or nonstructural maintenance. Many non-structural maintenance treatments are low cost and directly contribute to extending the life of the bridge, when executed in regular intervals. Areas considered to be nonstructural maintenance include debris cleaning, sweeping, joint cleaning and repair, scupper or drainage cleaning, crack filling, deck patching, and guardrail repair.

### **Bridge Management Plans/Programs**

Bridge inspections and condition assessments are the first step in a preventative maintenance program. The inspection process consists of a visual evaluation of the structure to determine what deficiencies, if any, exist. The Highway Department closely follows WisDOT, and federal guidelines, in the bridge inspection process. The inspections generally focus on the superstructure, substructure, approaches, deck surface, and piers.

Following a thorough review of these bridge elements, a sufficiency rating is assigned to each bridge. A rating system is used to reflect the general conditions of the bridge conditions and helps prioritize the maintenance, repair, or replacement of specific structures. The ratings are a function of distress type, severity, and quantity present in the bridge deck, superstructure, and substructure.

The next step in the process is to utilize a bridge management software program to develop a comprehensive maintenance approach for all bridges and to identify specific bridge repairs, reconstruction, and other maintenance needs. A BMP encourages a proactive approach to efficiently manage all structures emphasizing preventative maintenance as opposed to reacting to structures that are in poor or deteriorating condition and may require extensive repairs or reconstruction.



### **Future Action**

Marathon County currently performs bridge inspections and ratings but could benefit from the use of a software program to help evaluate bridge conditions and prioritize appropriate maintenance measures. The County will benefit from the use of a software program in several ways including:

1. Aid in implementing the Governmental Accounting Standard Board's (GASB) Modified Approach for reporting the bridge infrastructure in governmental financial statements.
2. Provide a basis to elected officials and management for annual bridge maintenance funding.
3. Improve the structural integrity, sufficiency rating, and overall bridge ratings of a greater percentage of the bridges in the County which will be reflected in the GASB 34 Report.
4. Direct the program towards preventive maintenance.
5. Significantly reduce major repairs and replacements.
6. Provide cost saving to budgets in the community.
7. Allow for more efficient use of governmental resources.
8. Allow for better coordination with other department and utility companies.

### **Bridge Management Software**

The Highway Department should consider the use of a bridge management software program to enhance the current bridge inspection, rating, and evaluation process that currently exists. SMART and Pontis are two software programs capable of performing bridge management. It should be noted there are differences between the two programs which are discussed in the following.

### **SMART**

SMART is a web based asset management program that can be used for a BMP. A benefit of the SMART software is that this program consists of a web based interface that allows inspectors to access the database from remote locations, such as on-site for a bridge inspection. Since the bridge data can be accessed remotely, inspectors are able to quickly obtain historic data and previous inspections to aid in the current inspection and evaluation process. This is beneficial because it can save time and may prevent unnecessary trips back to and from the office to input data or obtain historic bridge data.



The SMART program also allows for customized inspection forms and reports which can add the Highway Department and Highway Committee in the planning and budgeting process. In addition to the bridge report, the bridge management database is used to generate various lists and reports for district maintenance crews and project planners. The program is also capable of storing photos or other supplementary information. However, the overall planning and evaluation tool is not as powerful as the Pontis program.

### Pontis

Pontis is a software tool developed by FHWA that records bridge inventory and inspection data, simulates bridge conditions, and develops a list of projects including both maintenance and reconstruction projects. Pontis is a commonly used bridge software program used by many state DOT's and local agencies across the country. Pontis generates reports to show network and project-level results and predicts individual bridge life-cycle deterioration and expense. With this information a budget analysis, both short and long term, can be prepared which can help decision makers identify the best use of limited funding.

Pontis can be used to program simulations to determine current and future needs, predict future performance, and develop project recommendations. This can be done based on a given budget or can be completed to consider "what if..." scenarios including:

- What if we... 1) Do nothing.  
2) Maintain current funding levels (status quo).  
3) Increase bridge funding.

Compared to the SMART program, Pontis is more widely used by state and local agencies and is generally more powerful in performing evaluations, scenario planning, project prioritization, and budget planning. Data input however is completed in the office and can not be completed remotely.



## **Project Prioritization**

An asset management plan, consisting of pavement and bridge programs, can help agencies better understand what they have in terms of their transportation infrastructure and how they can best maintain and extend the life of these valuable assets. The use of pavement and bridge software is a valuable tool in the project prioritization and decision making process. These software programs help decision makers make sound, efficient, and effective recommendations that extend the life of the transportation infrastructure and provide the greatest return on the expenditure of limited funding resources.

Project prioritization is incorporated into the pavement and bridge software programs and is perhaps the most important feature of these programs. Both programs evaluate countywide conditions, project future conditions, and identify the most cost-effective solutions. Ultimately, the information that is generated by the software programs can be used to assist the Marathon County Highway Department and Highway Committee in selecting which projects will be funded and implemented. Simply stated, the software programs use a “life cycle” approach to address the needs of the entire network (pavement or bridges) and projects are prioritized based on what maintenance and reconstruction projects will provide the most benefit for the entire transportation system. In essence, the following questions are asked and answered (for both pavement and bridges).

- What are the needs?
- What type of work should be preformed?
- What is the impact of deferring work?
- What should receive highest priority or be replaced first?

In conclusion, the adoption of a PMP and BMP provides the following:

- Systematic approach that promotes the preservation of existing infrastructure.
- Accountability - Defensible polices, plans, and programs that are supported by computer models.
- Increased efficiency and effectiveness in collection and management of data.
- A focus on maintaining the serviceability and safety of the transportation network (roads and bridges).
- Maximizing benefits to the traveling public including improved safety and minimizing agency costs.



## **Appendix B**

---

# **MARATHON COUNTY TRANSPORTATION POLICIES AND PROCEDURES PLAN**

---

Prepared for

Marathon County Department of Conservation, Planning and Zoning and Highway Department

**Implementation Plan      Technical Memorandum #4**

Prepared by  
URS Corporation  
November 2007



## **Introduction**

This memo includes:

- An overview of the implementation plan.

## **Implementation Plan**

Pavement management programs (PMP) and bridge management programs (BMP) across the country have proven to be beneficial in helping local agencies make better informed and more efficient transportation/infrastructure decisions. Technical Memorandum #3 discussed the benefits and identified how project prioritization occurs within the both pavement and bridge software programs. Should the Highway Department decide to utilize a pavement and/or bridge software package, it is important to understand that these programs are tools that help decision makers in the project selection and decision making process. Ultimately the decision makers must evaluate this information and determine what projects will be selected and when those projects will be completed.

The following sections provide information regarding the implementation of a PMP and BMP for Marathon County.

### **Implementation of a PMP**

The Marathon County Highway Department has an opportunity to expand the current practice of collecting and reporting pavement condition data to better assist in the planning, maintenance, and reconstruction process. The implementation of the PMP would build upon the continued use of PASER and WISLR and would not require additional software costs. The following steps would help in expanding the use of the WISLR pavement software and in developing a more complete PMP.

- 1) Review existing WISLR data.** It is important that the Marathon County Highway Department staff review the existing pavement condition data that is currently stored in the WISLR program. WISLR contains information regarding when roadways were constructed, repaired, construction materials, average daily traffic levels, etc. This information, along with any additional data contained in the WISLR database, should be reviewed for accuracy and when appropriate should be updated or corrected. This is a critical step that cannot be overlooked since the planning scenario and budgeting tools within WISLR rely on user inputs (transportation and pavement data) to generate maintenance and budget recommendations. If the data is not accurate, the recommendations may not be accurate. Adequate time should be set aside to complete this task and this step should be complete before proceeding with any planning or budgeting analysis.
- 2) Continue using PASER to rate pavement conditions.** The Highway Department should continue to use PASER to rate the county pavement conditions. This will ensure that future pavement condition ratings are consistent with historical pavement condition ratings. If possible, the same individuals should try to record pavement ratings or at a minimum anyone involved in





recording pavement condition ratings should review, as a group, the various descriptions of the rating system to maintain consistency in the data collection and evaluation process.

- 3) **Use WISLR to update maintenance and reconstruction projects.** The WISLR program provides a five-year planning tool that prioritizes projects on a yearly basis. This information can be extremely useful to the Highway Department and Highway Committee in identifying what maintenance and reconstruction projects are needed for both the current year and upcoming years. The Highway Department, using WISLR, should prepare a tentative list of potential maintenance, repair, and reconstruction projects. These projects should be reviewed with the Highway Committee to consider the potential impacts and benefits. After a discussion of projects, the Highway Committee might choose to program the recommended projects for construction or it may be necessary to proceed to the following step (item #4).
- 4) **Use WISLR to conduct “what if…” scenarios.** At times it may be useful to conduct “what if…” scenarios to help the Highway Department, Highway Committee, and the general public to understand the potential impacts of deciding to do or not do a specific repair or reconstruction project. This is perhaps the most powerful use of WISLR in that the Highway Department staff can evaluate different scenarios (such as, increasing or decreasing the amount spent on pavement maintenance, deciding when a reconstruction project should occur, etc.) and then evaluate the impacts and benefits. This is also a useful tool to help convey information and educate the public about what might happen if a certain decision is or is not made.
- 5) **Repeat the process.** Once the projects have been programmed for maintenance or reconstruction, this process should start over again (item #1) by reviewing the data for accuracy and collecting pavement ratings at the next scheduled time.

### **Implementation of a BMP**

The Marathon County Highway Department has a well defined bridge inspection process but have an opportunity to enhance the process by adding a bridge software program to aid in the evaluation and the maintenance and reconstruction process. The following steps would help in developing a more complete BMP.

- 1) **Purchase a bridge software program.** WisDOT has no plans to incorporate bridge data into the WISLR program so this option would require an additional expenditure by the Highway Department. Should the Highway Department and Committee decide to purchase a bridge software program, Technical Memorandum #3 identified two possible software applications – SMART and Pontis. Both programs would aid in the bridge evaluation process but each provides different options. If the focus is on bridge evaluation and scenario planning (much like the WISLR program for pavement conditions) then Pontis provides the greatest benefit. Pontis contains tools that help identify and prioritize specific bridge improvements (which are likely more a bigger benefit to the Highway Department and Highway Committee). Furthermore, the reports and other data generated in the Pontis would be more valuable in conveying information to the public. If the focus is on enhancing the data collection



process, then SMART provides remote, web based access to data which can be helpful in the field. However, SMART does not offer as powerful planning tools as Pontis.

- 2) **Data collection and database archiving.** Once a software application is selected, the Highway Department would need to enter the historic bridge data into the database. Any future bridge inspection reports would also then be entered into the database. All the information necessary to manage the integrity of Marathon County's bridge structure system would be self contained within the bridge software. The bridge data would be easily accessible to help generate reports and this information should be integrated with the GIS to provide mapping capabilities. The database should also be setup to easily transfer data to WisDOT and other agencies.
- 3) **Perform deterioration modeling and project prioritization.** The Highway Department staff (licensed bridge engineers) would use the bridge software to perform deterioration modeling and project prioritization (similar to the process described for pavement management section). Bridge engineers would review and prioritize the needs identified by the inspectors and then use the bridge software program as a planning tool to assist the Highway Department and Highway Committee in identifying what bridge maintenance and reconstruction projects may be needed (current year and future years). The Highway Department, using the bridge software, should prepare a tentative list of potential maintenance, repair, and reconstruction projects. These projects should be reviewed with the Highway Committee to consider the potential impacts and benefits. After a discussion of projects, the Highway Committee might choose to program the recommended projects for construction or it may be necessary to proceed to the following step (item #4).
- 4) **Use the bridge software to conduct "what if..." scenarios.** At times it may be useful to conduct "what if..." scenarios to help the Highway Department, Highway Committee, and the general public to understand the potential impacts of performing or not performing a specific bridge repair. The Highway Department staff can evaluate different scenarios and then consider the impacts and benefits. This is also a useful tool to help convey information and educate the public about what might happen if a certain decision is or is not made.
- 5) **Continue alternating Township and County bridge inspections.** As required by Wisconsin law, the Highway Department will continue to perform bridge inspections alternating between Township and County bridges every other year. Depending on the year, this process should be updated for Township bridges one year and County bridges the next year. These results should be considered together to identify the best use of limited funding resources.